

**SPECTROSCOPY
PREAMPLIFIER
Model 2001/2001A**

Operator's Manual

SPECTROSCOPY PREAMPLIFIERS
Model 2001/Model 2001A

CONTENTS

	Page
1 INTRODUCTION	1-1
2 SPECIFICATIONS	
2.1 Inputs	2-1
2.2 Outputs	2-1
2.3 Performance	2-1
2.4 Connector Types and Cables	2-2
2.5 Power Requirements	2-3
2.6 Physical	2-3
3 ADJUSTMENTS AND CONNECTORS	
3.1 General	3-1
3.2 Front Panel	3-1
3.3 Rear Panel	3-2
3.4 Internal	3-2
3.5 Adjustment Procedure	3-3
4 INSTALLATION	
4.1 General	4-1
4.2 Detector Mounting	4-1
4.3 Precautions	4-1
5 OPERATING INSTRUCTIONS	
5.1 General	5-1
5.2 Initial Setup	5-1
5.3 Initial Checkout	5-1
5.4 Common Operating Problems	5-2
6 THEORY OF OPERATION	
6.1 General	6-1
6.2 Detailed Circuit Description	6-1
7 DIAGRAMS	
Schematic Preamplifier Model 2001	C-15642

SPECTROSCOPY PREAMPLIFIERS

Model 2001
Model 2001A

Section 1

INTRODUCTION

The Canberra Model 2001 represents the latest advance in charge sensitive preamplifiers. It was designed primarily for high resolution gamma spectroscopy using cooled Ge solid state detectors. The preamplifier converts the ionization charge developed in the detector during each absorbed nuclear event to a step function pulse output whose amplitude is proportional to the total charge accumulated in that event. The pulse decays exponentially with a time constant of 50 microseconds (nominal) to segregate successive events in high count rate applications.

The design of the Model 2001 includes a FET input circuit optimized to the ultra-high source impedance characteristics of Ge detectors. As can be seen in the functional schematic (Figure 1-1), the first stage functions as an operational integrator yielding an output voltage proportional to the accumulated charge. The second stage functions as a selectable gain differentiator/buffer and provides the separately terminated Energy and Timing outputs. Conversion factors of nominally 100mV/MeV or 500mV/MeV (Ge) are selected by a jumper plug on the printed circuit board inside the unit. The higher scale factor is especially useful for best signal-to-noise ratio in experiments involving low energy sources. The differentiator circuit includes a pole/zero adjustment to return the unipolar pulse signal to a reference or baseline level without overshoot. The first stage output is available at a rear panel test jack for detector/preamplifier troubleshooting. The V-I characteristics of the detector can be readily checked by measuring the test-point voltage as a function of detector bias voltage.

The Model 2001 is offered in two configurations: the standard unit is direct coupled at the input, for installations in which both terminals of the detector are electrically isolated from ground and in which the preamp can be directly mounted to the neck of the cryostat; the 2001A is capacitor coupled between the detector and preamp, for installations in which one terminal of the detector is grounded or in which the detector must be connected through cabling.

The performance of the Model 2001 is the current state of the art for room temperature (non-cooled) preamps. The noise level for the 2001 version (direct coupled) is equivalent to less than 600 eV FWHM (Ge) with a source capacitance of 0 pF, using 2 microsecond near Gaussian pulse shaping, and degrades to less than 17 eV/pF. The 2001A (AC coupled) offers less than 630 eV FWHM (Ge), the difference owing to the current noise in the detector bias resistor and the additional capacitance at the input using the SHV connector. Typical noise performance with other pulse shaping time constants can be seen in Figure 2-1.

The count rate capability of the Model 2001 has been demonstrated in excess of 200,000 counts per second using a Co^{60} gamma energy source (1.33 MeV peak). The fast rise time is maintained over a wide range of detector source capacitance, and is more than adequate for the charge collection times of planar or coaxial Ge detectors.

In order to take advantage of the high count rate capability of the 2001, a high count rate main shaping amplifier, such as the Canberra Model 2010 is recommended. Other amplifiers may have count rate limits of their own. Timing analysis may be done with such units as the Canberra Model 1427 ARC Timing Unit, or other NIM modules as needs dictate. At low energies, the system timing performance may benefit from the higher gain setting of 500 mV/MeV.

A test input is provided on the Model 2001 to assist system setup and simple troubleshooting. The capacitor value is certified in the unit test report for reference use as a secondary charge calibration standard. The nominal voltage gain through the preamplifier test input is 1X for the output scale factor of 100mV/MeV, and 5X for the output scale factor of 500mV/MeV.

Power for the Model 2001 is usually supplied from the associated Canberra pulse shaping amplifier. The power lines are filtered within the Model 2001 to provide high noise immunity. A ten foot power cable is provided with the preamp.

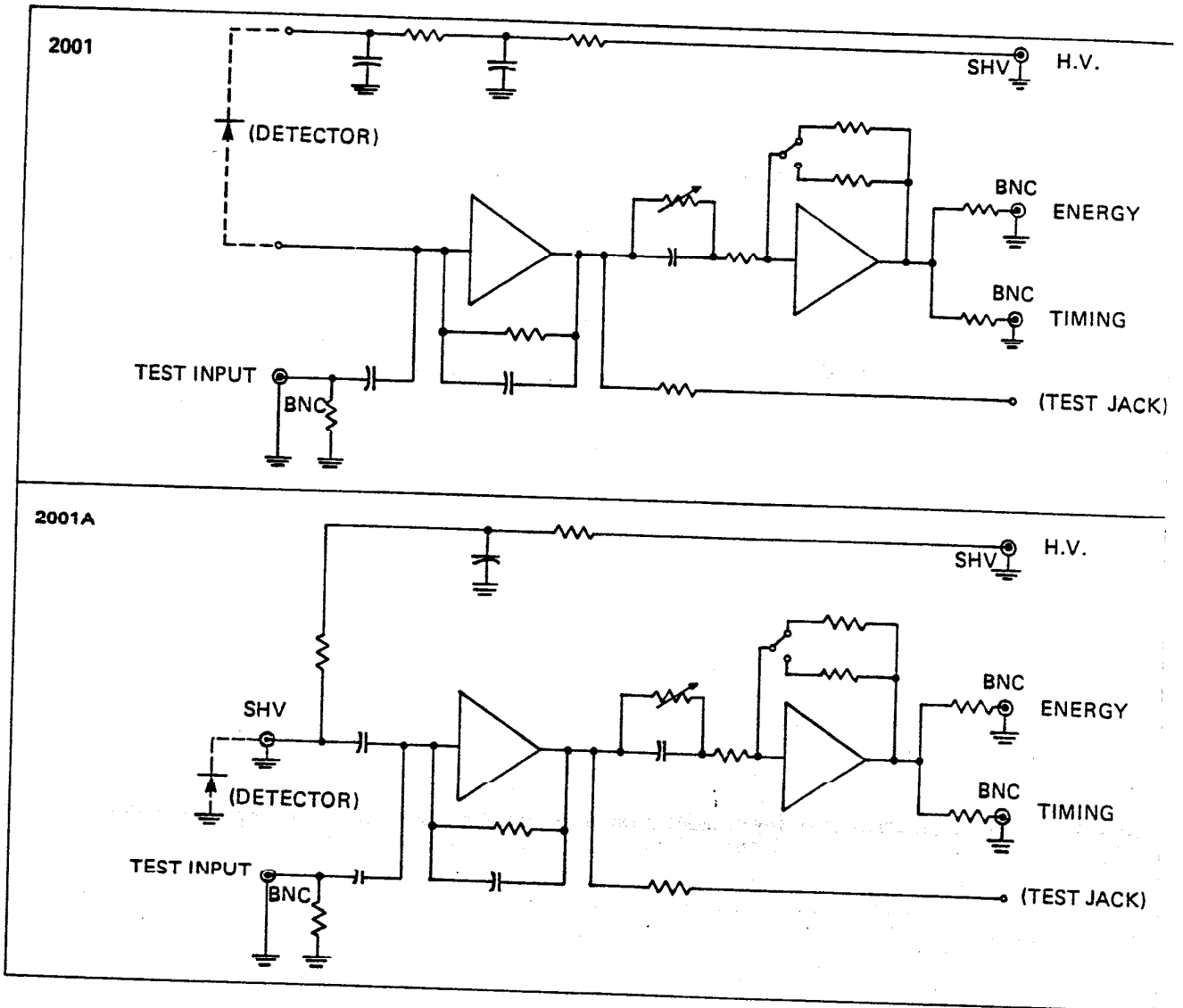

Figure 1. Functional Schematic, Model 2001.

Section 2 SPECIFICATIONS

2.1 INPUTS

DETECTOR INPUT

Accepts the positive or negative charge pulse from a cooled Ge(Li) detector. The practical limit of operation may best be described as a product of energy and count rate of up to 200,000 MeV/second, with a single impulse limit of 200 MeV equivalent charge(Ge).

TEST INPUT

Accepts a positive or negative signal, which is then differentiated as a charge coupled signal to the preamp input at nominally 0.5 picocoulomb/V. Voltage gain to the Energy or Timing outputs is nominally 1X, or 5X, depending upon selection of preamp sensitivity of 100 mV/MeV or 500 mV/MeV, respectively. Input impedance is 93 ohms.

HV INPUT

Detector bias voltage, 0 to ± 5000 VDC. No limit to the rate at which bias may be applied, as filter time constant internal to preamp is 10 seconds nominal. Series resistance to detector bias point is 10,000 Megohms nominal.

2.2 OUTPUTS

ENERGY OUTPUT

Provides unipolar pulses linearly proportional in peak amplitude to the charge input, non-inverting. Decay time constant is 50 microseconds ($\pm 10\%$). Output swing range is ± 10 V open circuit. Output impedance is 93 ohms, series connected, DC coupled. Output D.C. offset is 0 ± 75 mVDC (at gain of 100 mV/MeV), or 0 ± 300 mVDC (at gain of 500 mV/MeV).

TIMING OUTPUT

Provides a unipolar pulse for each input event, with signal parameters same as for Energy output, except output impedance is 50 ohms.

2.3 PERFORMANCE

INTEGRAL NONLINEARITY

Less than $\pm 0.05\%$ for an output swing of at least ± 8 V (unterminated).

GAIN STABILITY

Better than $\pm 0.005\%/^{\circ}\text{C}$ (± 50 ppm/ $^{\circ}\text{C}$) over a range of 0 to $+50^{\circ}\text{C}$. Better than $\pm 0.01\%$ over 24 hours at constant temperature after 1 hour stabilization.

CHARGE SENSITIVITY

2V/picocoulomb, or 10V/picocoulomb, corresponding to 100 mV/MeV, or 500 mV/MeV (Ge) equivalent, as selected by jumper plug on printed circuit board internal to the unit. Shipped in the 100 mV/MeV gain position. Gain tolerance is $\pm 25\%$ due to absolute tolerance of component parts.

NOISE

Using a Canberra Model 2020 Spectroscopy Amplifier set at 4 μ sec Unipolar Semi-Gaussian shaping, noise behavior is summarized as follows:

C _{source} in picofarads	for	Noise in	
		Coulombs, RMS	keV, FWHM *
0	2001:	typical	1.3×10^{-17}
		maximum	1.4×10^{-17}
	2001A:	typical	1.4×10^{-17}
		maximum	1.4×10^{-17}
100	2001:	typical	5.0×10^{-17}
		maximum	5.2×10^{-17}
	2001A:	typical	5.1×10^{-17}
		maximum	5.3×10^{-17}

* based upon 2.98 eV/ion-pair in Ge @77°K

Noise performance for other shaping time constants and source capacitances is depicted in Fig. 2-1.

Less than 40 nSec with C_{source}=0pF, and less than 50 nSec with C_{source}=100 pF.

Count rate performance has been demonstrated at beyond 200,000 counts per second for a Co⁶⁰ source (1.33 MeV), averaged at a rate of 75,000 MeV/second.

RISE TIME

COUNT RATE

2.4 CONNECTOR TYPES AND CABLES

DETECTOR INPUT

On 2001, 1 inch (nominal) leads with Augat LSG-3CG1-1 sockets (fit 0.040" dia. pins), for direct mounting to common feedthroughs on detector cryostats.

On 2001A, SHV with dust cap and chain, BNC CW-123A/U.

HV INPUT

SHV

TEST INPUT

BNC UG-1094/U

ENERGY OUTPUT

BNC UG-1094/U

TIMING OUTPUT

BNC UG-1094/U

POWER

Amphenol 17-20090

CABLE

A ten foot power cable with required connectors is supplied with the preamplifier.

2.5 POWER REQUIREMENTS:

+12 VDC - 10 mA
- 12 VDC - 5 mA
+24 VDC - 30 mA
- 24 VDC - 10 mA

Supplied from associated main shaping amplifier,
or Canberra Model 1409 Preamplifier Power
Supply.

2.6 PHYSICAL

SIZE

See Fig. 2-2 for details

NET WEIGHT

13 ounces (0.81 kg)

SHIPPING WEIGHT

Approximately 30 ounces (1.9 kg)

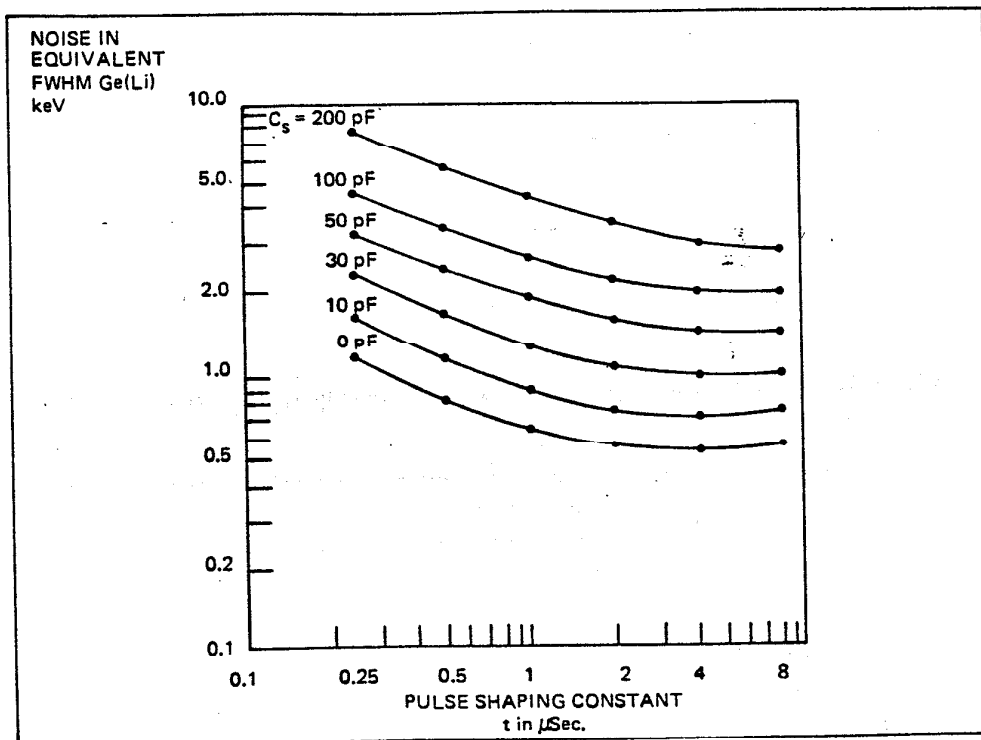

Figure 2-1
Typical Electronic Noise Behavior of Model 2001
for various pulse shaping time constants.

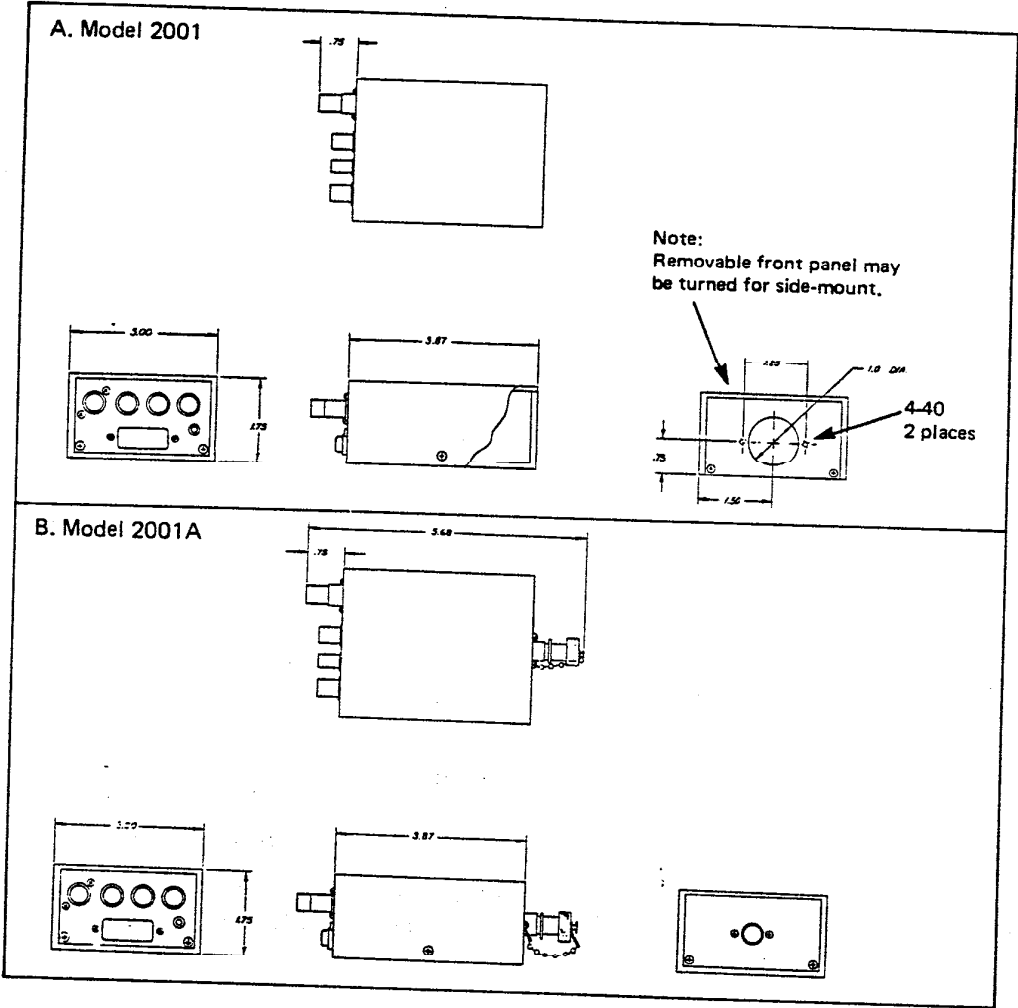

Figure 2-2
Outline Drawing.

Section 3
ADJUSTMENTS AND CONNECTORS

3.1 GENERAL

Complete understanding of the purpose of the adjustments and connectors is required for the proper operation of the Model 2001 or 2001A preamplifiers, and it is recommended that this section be read before proceeding with the operation of the instrument.

3.2 FRONT PANEL

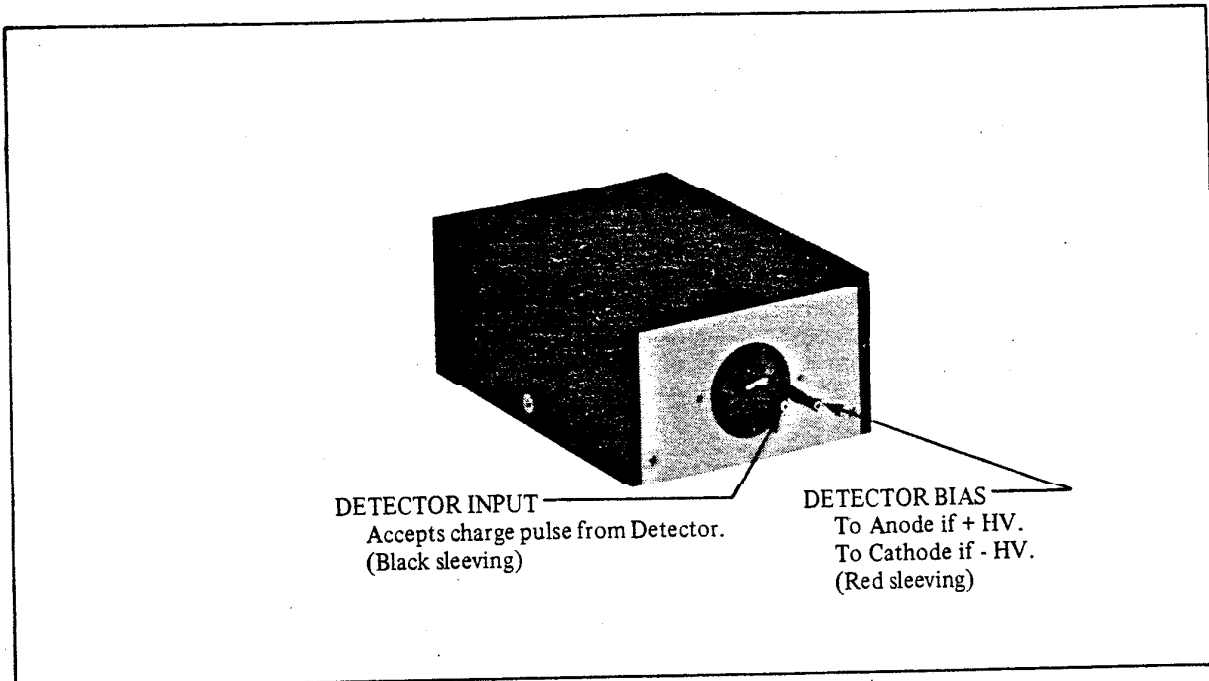

Figure 3-1
Front Panel, Model 2001

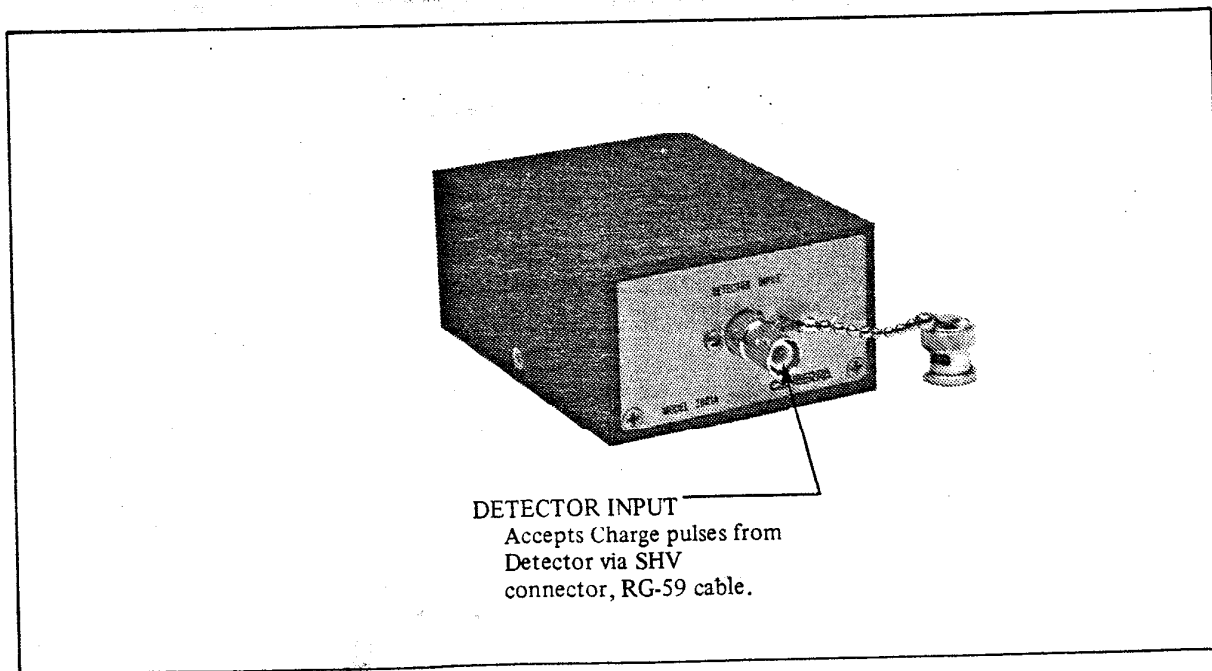

Figure 3-2
Front Panel, Model 2001A

3.3 REAR PANEL

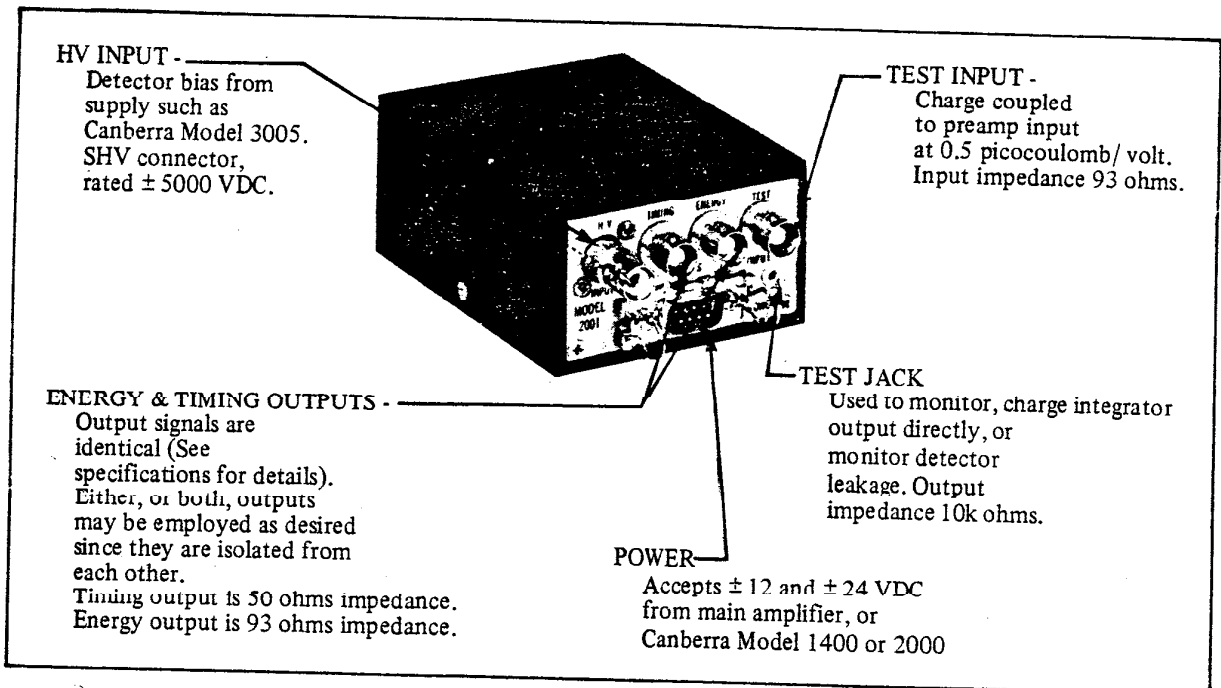

Figure 3-3
Rear Panel, Model 2001

3.4 INTERNAL

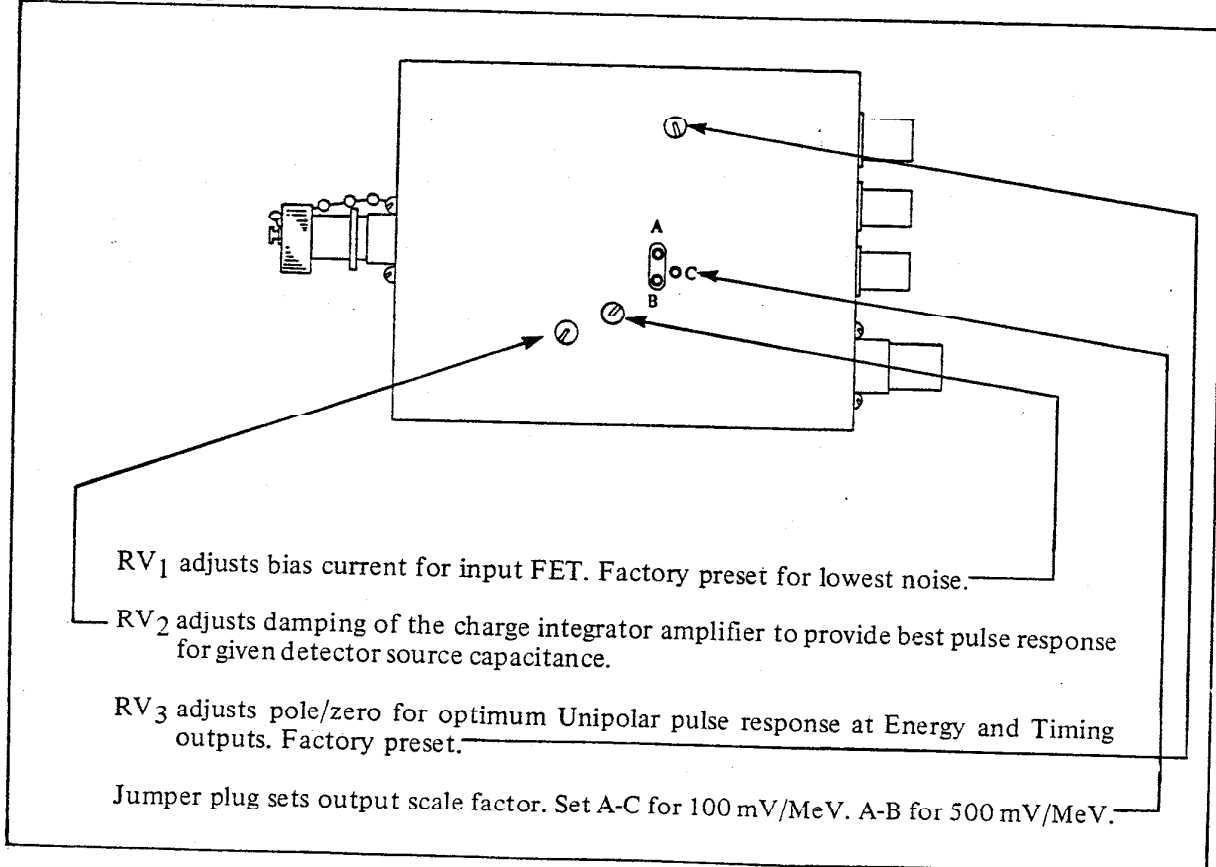

Figure 3-4
Internal Adjustments, Model 2001

3.5 ADJUSTMENT PROCEDURE

While the Preamplifiers have been carefully calibrated at the Factory, the user may desire to alter either the Pole/Zero or Risetime/Damping Adjustments for specific experiments.

The following procedures detail the most effective method of making the desired adjustments. They may be performed either on a Test Bench, or with the Preamplifier mounted to the Cryostat Neck (Model 2001). The user is advised to defer making these adjustments until he has read Sections 4 and 5 (Installation, and Operating Instructions).

Required Equipment:

- a) Function Generator providing variable 0-10 Volt Square Wave Output, with Rise Time less than 25 nSec, and a Sync Output (HP 3310, Data Dynamics 5109, or equivalent).
- b) Calibrated Oscilloscope, rated DC-150MHz minimum (Tektronix 454, 475, or equivalent).

3.5.1 POLE-ZERO TRIM

The following method uses the Function Generator square wave output to calibrate the Pole-Zero precisely, in lieu of the more common approximations made using various gamma ray sources presented to the detector. The adjustment is properly an electrical one, and is not influenced by detector variances. Hence it is usually set just once. The same technique is equally valid for the Preamp-Amplifier interface in adjusting the Amplifier's input differentiator Pole-Zero. That setting does change between each Preamplifier and Amplifier, and the instructions which follow provide the optimum setting here as well.

- 1. Verify Bin power is OFF before making connections to preamp. Scope and function generator should ON, and warmed up. Amplifier should be installed in Bin, or wired to Bin power source.
- 2. Connect preamp power cable between preamp and Amplifier.
- 3. Connect shielded cables BNC/BNC between:

- Preamp timing output and Scope channel B input;
- Function Generator SYNC output and Scope external Trigger input;
- Function Generator signal output and Preamp test input, with "tee" to Scope channel A input.

- 4. Set:

- Function Generator Output 1 volt pk-pk square wave
- Frequency 500 Hz

Scope:

- Channel A 0.5 V/cm, DC coupled
- Channel B 2 V/cm, DC coupled
- Display alternate, ext triggered, 200 μ sec/cm

Set jumper plug inside Preamplifier to "A" and "C". Apply power to the Bin power supply.

- 5. Apply power to the Bin power supply. Observe scope dual trace for display as shown in the following picture:

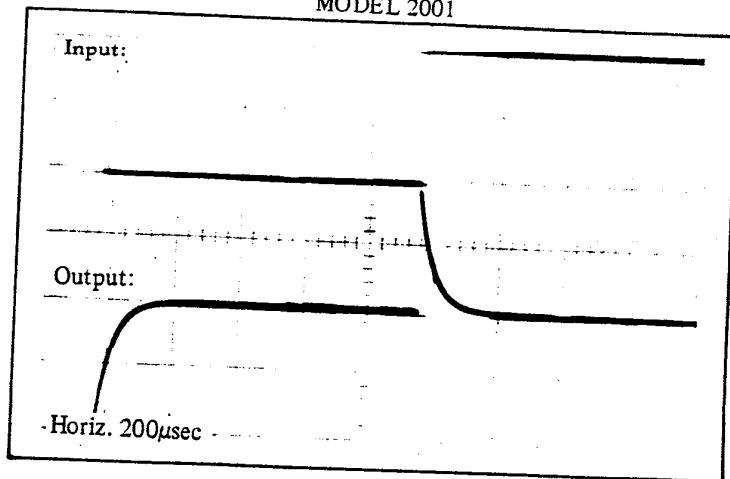

- Set scope to display Channel B only. Increase Function Generator level for a display of at least 6V pk (12V pk-pk).

The following clamp circuit will be very useful in establishing the Pole-Zero trim. It should preferably be mounted in a miniature box. (e.g. Pomona 2417, with BNC plugs to attach directly to scope input).

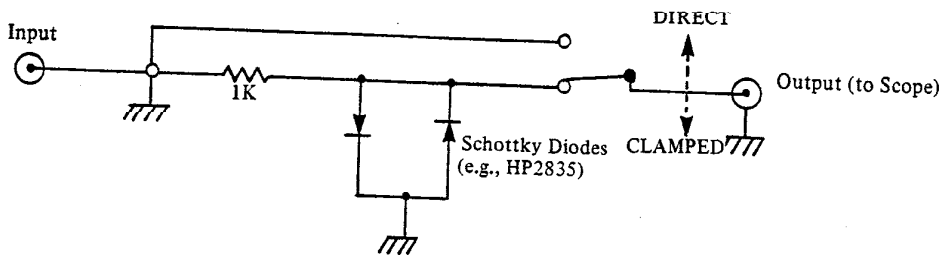

- Install Schottky clamp box on input to Channel B, reconnect coax cable. Set switch to DIRECT and verify wave form essentially same as in (2) above.
- Set switch to CLAMPED, change scope to 20mV/cm (vert.) and 1 mSec/cm (horiz). Set Function Generator frequency to 100 Hz. Now adjust RV3 for best pulse response as illustrated in center trace of photo below. Proper compensation requires a flat line, without overshoot or long tailing. Preamp Pole/Zero is now set precisely.

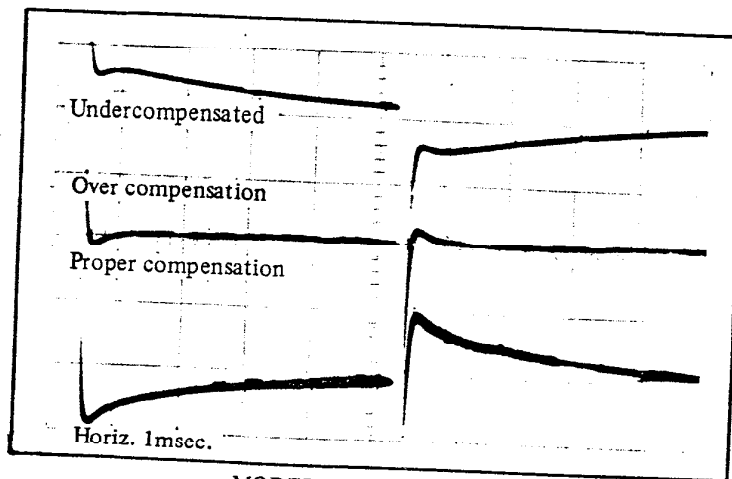

MODEL 2001
AMPL. POLE/ZERO TRIM

9. Reduce Function Generator output to minimum, set frequency to about 500 Hz. Move coax cable on scope Channel B from Preamp TIMING output to Amplifier unipolar output, and add a coax cable between Preamp ENERGY output and Amplifier input.

10. Set Amplifier controls as follows:

Gain: X 100 (using coarse and fine controls).
Shaping: 2 microseconds
Range: 10 volts
Input Polarity: positive
Output Polarity: positive
Restorer: OFF

11. Set switch on Schottky clamp box to Direct. Adjust Function Generator for a scope Channel B display of 20V pk-pk, using 5V/cm scale, and time base of 200 μ Sec/cm.

12. Set switch on Schottky clamp box to CLAMPED, change scope display to 100mV/cm and adjust the Amplifier Pole/Zero front panel trim pot for best pulse response as below.

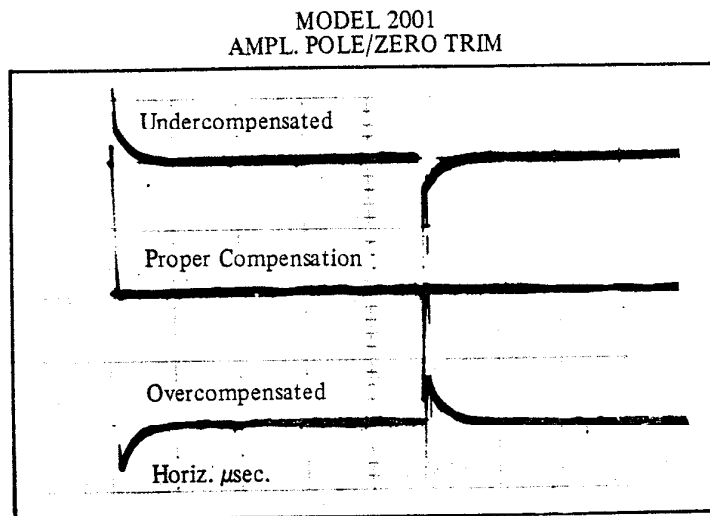

Amplifier Pole/Zero is now set precisely.

The above procedure may seem lengthy at first, but it is really quite simple and straightforward.

3.5.2 DAMPING TRIM

1. Using setup from above, move coax cable on scope channel B from Amplifier output to Preamplifier TIMING output again. Adjust Function Generator frequency to about 100 kHz, and output level for a display of 1 volt peak on Channel B.
2. Set scope time base to 50 nsec/cm and observe rise time. Adjust RV2 for cleanest waveform (by reference to photographs on Following Page) for the detector source capacitance used. Note that the optimum setting (and output risetime) does change slightly depending upon the output scale factor used.

MODEL 2001
DAMPING TRIM

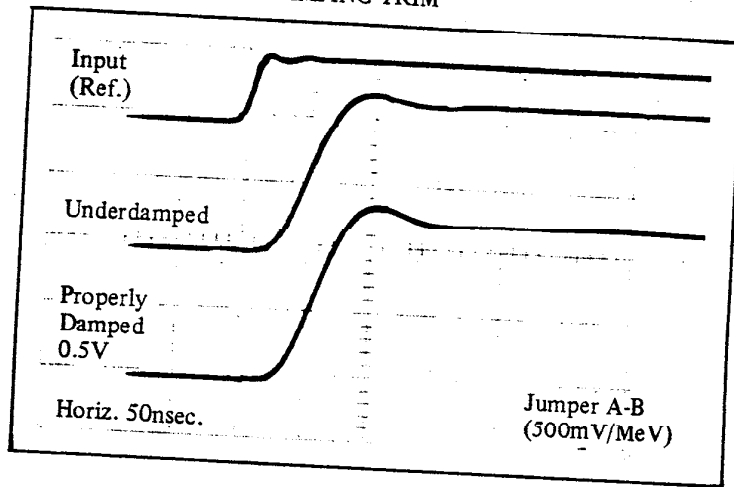

MODEL 2001
DAMPING TRIM

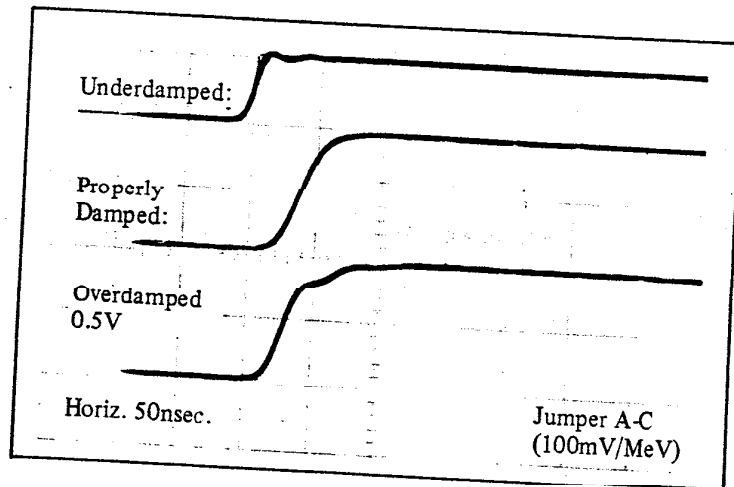

Section 4 INSTALLATION

4.1 GENERAL

The Canberra Model 2001 is direct coupled at the input, for installations in which both terminals of the detector are electrically isolated from ground, and in which the preamp can be directly mounted to the neck of the detector cryostat.

The Canberra Model 2001A is capacitor coupled at the input between the detector and the FET, for installations in which one terminal of the detector is grounded; or in which the detector must be connected thru cabling.

4.2 DETECTOR MOUNTING

The front panel of the Canberra Model 2001 is reversible to facilitate either end-mounting, or side-mounting to the cryostat as desired. The panel provides a 1 inch diameter opening for routing the input leads to the detector feedthru pins, and 2 #4-40 tapped holes for mounting an adapter bracket for the particular cryostat neck.

Mounting may be accomplished most readily and conveniently if the cover is removed from the preamplifier. *However, the user must be very cautious not to touch the high voltage capacitors or high Megohm resistors in the detector bias supply to avoid fingerprints and residue which will degrade noise performance.* It is also suggested that the input leads be dressed away from each other, and the chassis to minimize the stray capacitances which aggravate noise.

4.3 PRECAUTIONS

The user must be very cautious in inspecting or adjusting the Preamplifier, particularly in the area of the high voltage components as described above.

While the long filter time constant relieves restrictions on the rate of voltage applied to the HV INPUT, *the user should never connect or disconnect the Preamplifier from a detector while the high voltage is ON.* Always wait at least 5 minutes after the detector bias has been reduced to zero (allowing the filter to fully discharge back into the High Voltage Power supply), before disconnecting the preamplifier from the detector.

Special precautions, and possible special treatment at the factory, may be necessary if the Preamplifier is to be used in an environment of high relative humidity to minimize extraneous noise or possible destruction of the FET due to high voltage leakage and discharges.

Strict attention must be applied to the preceding precautions in order to insure optimum performance and reliability. Since the Model 2001/Model 2001A is a state-of-the-art ultra-low noise preamplifier, field repairs are not recommended.

Section 5 OPERATING INSTRUCTIONS

5.1 GENERAL

The purpose of this section is to familiarize the user with the Model 2001 or Model 2001A Spectroscopy Preamplifier, and to check that the unit is operating correctly. Since it is difficult to determine the exact system configuration in which the unit will be used, explicit operating instructions cannot be given. However, if the following procedure is carried out, the user will gain sufficient familiarity with the instrument to permit its proper use in the system at hand.

The instructions which follow may be best carried out with the Preamplifier on a test bench, separated from the detector. For the Model 2001, the input leads should be dressed back away from the access hole, and the metal hole plug supplied with the unit installed securely. For the Model 2001A, keep the dust cap secured on the input SHV connector.

Because the input is charge sensitive, and ultra high impedances are involved, the Preamplifier is inherently somewhat microphonic. Testing should only be done with the Preamplifier chassis cushioned on a block of foam rubber, and the cover securely fastened to the frame.

The charge gain of the preamplifier is set by the position of a jumper plug in the approximate center of the printed circuit board. The preamp is shipped with the jumper set from "A" to "C", giving a nominal charge gain of 2 V/picocoulomb, equivalent to approximately 100 mV/MeV, and the nominal voltage gain between TEST input and ENERGY (or TIMING) outputs is 1. With the jumper set from "A" to "B", the nominal charge gain is 10 V/picocoulomb, equivalent to approximately 500 mV/MeV, and the nominal voltage gain between TEST input and ENERGY (or TIMING) outputs is 5. Set the jumper to the scale factor desired before use.

5.2 INITIAL SETUP

1. Connect the Preamplifier to a source of low voltage power (± 12 and ± 24 VDC) such as from a Canberra main shaping amplifier or from the Model 1409 Preamp Power Supply, using the ten-foot cable provided. Keep Power OFF initially.
2. Connect the ENERGY output of the Preamplifier to one input channel of a dual trace oscilloscope. Set the vertical sensitivity to 1 V/cm, DC coupled, and the time base to $10\mu\text{sec/cm}$.
3. Connect the ATTENUATED output of a tail pulse generator (such as the Canberra Model 1407 Reference Pulser) to the TEST input of the Preamplifier, with a "tee" connection to the second input channel of the oscilloscope. Set the Pulser to + output, 90 Hz, minimum risetime and maximum falltime. Set the vertical sensitivity of the oscilloscope second channel initially at 0.05 V/cm, D.C. coupled.
4. Connect the Pulser DIRECT output to the oscilloscope trigger input and set the oscilloscope up for external triggering on + slope.

5.3 INITIAL CHECKOUT

1. Switch the main power ON now.
2. Adjust the Pulser output for a 200 mV peak positive pulse. Observe the Preamplifier output to be approximately 200 mV peak positive (for 100 mV/MeV scale factor), or 1V peak positive (for 500 mV/MeV scale factor).
3. Increase the Pulser output until the Preamplifier positive output pulse clips. Verify level is $\geq 10V$.

4. Invert the test pulse polarity and repeat above steps 2 and 3 for negative output gain and swing range. Note that the output signal polarity is non-inverting (in phase) referred to the input.

5. Reduce the Pulser output to 20 mV peak, and set the polarity to positive.

6. Connect the Preamplifier ENERGY output to the input of a low noise Spectroscopy Amplifier (such as the Canberra Model 2010), and move the oscilloscope first channel input to the Amplifier Unipolar output. Set the amplifier to 2 μ sec shaping.

7. Connect an AC Voltmeter to the Amplifier Unipolar Output, using a "tee" connection with the oscilloscope lead. If the Voltmeter is a true RMS type, adjust the Amplifier coarse and fine gain for a peak output pulse as follows:

$$e_{pk} = \frac{C_{Test} \text{ (pF)}^*}{0.5 \text{ (pF)}} \times 4.38V$$

If the Voltmeter is an average reading type calibrated to read RMS on a sinusoid, set the Amplifier gain for a peak output pulse as follows:

$$e_{pk} = \frac{C_{Test} \text{ (pF)}^*}{0.5 \text{ (pF)}} \times 4.86V$$

*Note: For actual value, see schematic B-15642

With the above calibration, the meters will be calibrated to read 10 mV=1 keV of system noise in equivalent F.W.H.M. for (Ge).

8. Switch the Pulser OFF, and disconnect it from the Preamp TEST input. Read the 0 pF noise of the Preamp plus amplifier on the Voltmeter. Note: A slightly lower reading is obtained using the higher scale factor (jumper plug from "A" to "B") by virtue of the improved noise weighting between Preamp and Amplifier.

9. Noise tests may be made for simulated detector source capacitances by adding test capacitors (properly shielded) to the input. For the Model 2001, these should be on teflon standoffs, mounted in a shielded box. For the Model 2001A, the capacitors should be mounted in SHV connectors. The capacitors must be a low noise type, preferably porcelain.

5.4 COMMON OPERATING PROBLEMS

The modern Ge(Li) gamma ray spectrometer is an extremely sensitive, state-of-the-art system. Inexact performance of other than the grossest type is generally due to subtle factors. It is the ability to determine and correct these factors that constitutes the art in the science of gamma spectroscopy instrumentation.

All of the many possible contributors to less than optimum performance cannot be listed here. The purpose of this section is to note the usual causes of loss of resolution, and to suggest curative steps.

Do not expect to diagnose problems with a detector, a preamplifier, a main amplifier, and a multichannel analyzer. The spectroscopy system records results, it does not lead to the identification of causes. A good, modern, oscilloscope (Tektronix 581, 585, 453, 454, 544, 547) will be needed. Also, a high quality tail pulse generator (Canberra 1407 or equivalent) will be extremely useful.

The simplest test is, of course, to connect your detector, apply bias, present a source, and accumulate a spectrum. Be sure a pulser is not feeding the preamplifier while the spectrum is accumulating, or resolution loss may result. If the results obtained are far different from what is expected, it then becomes necessary to trouble shoot the system.

First, observe the amplifier output on an oscilloscope at various time base and amplitude settings. Is the amplifier properly pole/zero cancelled (do the output pulses cause undershoots that persist for longer than two or more main pulse widths)? The Canberra 2020 series Spectroscopy Amplifiers have a built-in DC Restorer. Set the main amplifier pole/zero cancellation by the procedure given in the amplifier manual.

The next step is to remove all sources and, with the detector still connected and bias applied, to apply a test pulse to the TEST input of the preamplifier. Make sure the pulser polarity is correct. Set the amplitude of the pulser so that its peak occurs near the region of the peak of the source previously used.

Observe the output of the amplifier without DC restoration. Note that the amplifier is not properly pole/zero cancelled for the pulser feeding the preamp (due to the extra time constant of the pulser). This is of no consequence for a pure pulser input. Are the baseline fluctuations of 60 or 120 Hz frequency? A ground loop is indicated. Insert *all* system line plugs into the same outlet. Or, are the baseline fluctuations of random frequency between 10 Hz and 15,000 Hz? If so, clap your hands near the detector and look for increased noise of this type. The area may be too noisy, causing microphonic problems.

Isolate the detector as much as possible by setting it on a foam rubber base and place a foam rubber collar between the bottom of the cryostat head and the Dewar neck. The bubbling of the liquid nitrogen in the Dewar is a frequent, hard-to-cure cause of microphonics.

If low frequency noise still is a serious problem, it may be necessary to use the Low Rate mode of the Canberra main amplifier's built-in DC restorer.

If high frequency noise is observed, is it random or periodic? Periodic noise is a sign of electronics failure: isolate the cause by observing the preamplifier output. Is the same pattern observed, or is the problem in the main amplifier? Random high frequency noise may be detector load resistor or input capacitor breakdown.

Next, accumulate a pulser peak on the analyzer. Calculate its resolution. Repeat with the detector removed and the input connector of the preamplifier shielded. (Wait five minutes to remove the preamplifier from the detector after removing the detector bias.) You now have three resolution figures available for essentially equal energy peaks: source; pulser and biased detector connected; pulser without detector connected. Denote these by R_S , R_D , and R_E , respectively.

If R_E is not less than 0.65keV for two microsecond unipolar Gaussian shaping time constant, the problem is in the electronics and probably in the preamplifier.

If R_E is acceptable, but R_D is greater than 0.65 keV plus 0.017 keV/pF detector and connection capacitance, then the problem is either in the detector (microphonics, excess leakage current noise, breakdown due to moisture or grime on the detector output connector), or in the preamplifier (leaky input capacitor, dirty or moist detector load resistor, dirty or moist detector input connector).

If R_E and R_D are acceptable, but the live spectrum (R_S) is not as good as expected, the problem is probably in the detector (bad detector, poor charge collection, insufficient bias) or in the electronics following the preamplifier (count rate too high, improper amplifier pole/zero cancellation, wrong main amplifier time constant, wrong position of restore, wrong amplifier shaping- bipolar vs. unipolar, improper amplifier shaping for the ADC being used, ADC cannot take the count rate, amplifier or ADC drift).

These many alternatives are not easy to check. Substituting, one-by-one, other detectors, preamplifiers, amplifiers, and multichannel analyzers may help pinpoint the problem. Checking the above common problems will aid in spotting the source of trouble.

Going through the steps mentioned above help to eliminate obvious problems and will provide a good starting point for the final trouble shooting step. Call Canberra: 203-238-2351. With the information collected above, our advice will be far more concise and to the point.

Section 6 THEORY OF OPERATION

6.1 GENERAL (Refer to Schematic C-15642)

The Model 2001/2001A Spectroscopy Preamplifier essentially consists of 2 stages: an input charge sensitive section (integrator), and an output differentiator/buffer. The unit includes a decoupling network for the detector bias voltage, and provides options for a direct coupled input (Model 2001), or a capacitor coupled input (Model 2001A).

6.2 DETAILED CIRCUIT DESCRIPTION

The input section, consisting of Q1 thru Q7, forms an operational amplifier whose behavior is controlled by the feedback components C2 and R2. Viewed in this manner, the circuit is quite similar to an ordinary op amp using discrete components, with the exception that capacitors (C1 and C2, e.g.) are used instead of the usual resistors (R_S and R_F , respectively). The resistor R2 only serves to provide a DC bias path around the loop.

The input FET operates at a fairly low drain-to-source voltage (4 VDC nominal), and at a bias current level most conducive to high signal gain and low noise (15 to 20 mA). RV1 provides the current adjustment as necessary. The drain voltage is set by a bridge built around Q2 and Q3. Resistors R9 and R10 reference a voltage to the base of Q3, and the divider R6 and R7 then reflects this voltage down to the drain of Q1 (this is the voltage required to balance the differential amplifier Q2 and Q3). C4 and C5 are signal bypass capacitors.

The differential amplifier formed by Q2 and Q3 provides the very high non-inverting voltage gain from Q1 to the output. Q4 is a current source (sinks the current from Q3), and Q7 is an emitter follower which buffers the other circuit loads from the collector of Q3. Q6 is a regulator amplifier which maintains a constant voltage across R11 equal to its VBE by controlling the base bias of Q4. This makes Q4 an active current source with an output impedance of several megohms as a load to Q3. Q5 forms another simple current source thru R12. The currents thru Q4 and Q5 are then nominally 1 and 6 mA, respectively.

RV3 and C7 provide frequency compensation for the loop, and the combination may be set for cleanest pulse response as desired.

The DC voltage at the output of the integrator is brought out to the rear panel test jack for monitoring purposes. Without detector HV bias present, this DC level is the retard bias required on the gate of the FET to allow it to conduct the current demanded by RV1, etc. This voltage is nominally -0.75 VDC, but should never be > 0 , or more negative than -2 VDC.

The output amplifier made up of Q8 thru Q12 is a more conventional operational amplifier, with R15 as the R_S , and R27 or R28 as the R_F .

Q8 is a common emitter stage, driving the common base Q9 directly. The latter provides the voltage gain in the loop, and level translates the bias levels for an output voltage swing capability of up to $\pm 10V$. Q10 is a conventional current source, providing a nominal 3 mA sink to Q9. CR1 and CR2 provide the static forward bias for the push-pull emitter follower outputs Q11 and Q12. CR3 and CR4 act with CR1 and CR2 respectively to limit the voltage that can be developed between the output driving point and the bases of the push-pull transistors, and thereby provide short circuit current limiting thru R23 and R24. R25 and R26 provide the coax terminations for the Energy and Timing outputs respectively.

C15 and C16 are simple frequency compensation elements for the selected gain of the buffer.

C10 is the differentiating capacitor which in conjunction with R15 forms the nominal 50 μ sec tail pulse delivered to the output. RV3 and R13 shunting C10 act to soften the differentiating action, and prevent undershoot of the tail pulse output signal. Keeping this pulse precisely unipolar aids significantly in achieving the best resolution performance in the instrument system, and in optimizing overload recovery.

Standard LC decoupling of the ± 12 and ± 24 VDC supplies is used to minimize problems due to noise pickup and induction in the power cable external to the preamp.

10/10/10