

ORTEC

100 MIDLAND ROAD, OAK RIDGE, TENNESSEE, 37830
AREA CODE (615) 483-8451 TWX 810-572-1078

INSTRUCTION

MANUAL

417

FAST

DISCRIMINATOR

TABLE OF CONTENTS

	Page
WARRANTY	
PHOTOGRAPH	
1. DESCRIPTION	1-1
2. SPECIFICATIONS	2-1
3. INSTALLATION INSTRUCTIONS	3-1
3.1 General	3-1
3.2 Connection to Power—Standard Nuclear Instrument Module, ORTEC 401/402	3-1
3.3 Connecting Into a System	3-1
4. OPERATING INSTRUCTIONS	4-1
4.1 Front Panel Controls	4-1
4.2 Timing with Photomultipliers	4-1
4.3 Applications	4-2
5. CIRCUIT DESCRIPTION	5-1
5.1 Basic Operation	5-1
5.2 Circuit Detail	5-1
6. MAINTENANCE	6-1
6.1 Testing Performance	6-1
6.2 Tabulated Test Point Voltages	6-2
6.3 Factory Service	6-2
7. BIN/MODULE CONNECTOR PIN ASSIGNMENTS FOR AEC STANDARD NUCLEAR INSTRUMENT MODULES	7-1
Block Diagram and Schematic	
417-0101-B2 ORTEC 417 Block Diagram	
417-0101-S2 ORTEC 417 Fast Discriminator	

LIST OF FIGURES AND ILLUSTRATIONS

	Page
1. Step-Function Response of Transmission Line for Which Decibel Attenuation Varies as the Square Root of Frequency	3-2
2. Calculated Variation of T_0 with Cable Length for RG-58A/U, and RG-8/U	3-2
3. Simple Fast Slow Coincidence System	4-3
4. A Typical Coincidence Spectrum Using Plastic Scintillators	4-4
5. A Typical Coincidence Spectrum Using NaI (TI) Scintillator	4-6
6. Gamma-gamma Coincidence System With a Ge (Li-drifted) Detector	4-7
7. Timing Spectrum With Ge (Li-drifted) Detector	4-8
Typical System Block Diagrams	
Fast-Fast Coincidence (PMT) With Pulse Shape Discrimination	4-9
Fast Timing for (Semi-conductor Detector PMT) Coincidence Using Crossover Pickoff Technique	4-9
Gamma Ray Pair Spectrometer	4-10
Sub-Nano Second Timing System (Semi-Conductor-Photo Multiplier Tube)	4-10

ORTEC[®]
MODEL 417
**FAST
DISCRIMINATOR**

DISC. LEVEL



STRETCHER
IN



OUT

INPUT

NEG.



OUTPUT 1

NEG.



OUTPUT 2

POS.



OUTPUT 3

+12V 35mA
-12V 75mA
+24V 25mA
-24V 50mA

1. DESCRIPTION

The 417 Fast Discriminator is designed as a time derivation unit, primarily for use with photomultiplier tubes, but versatile enough to be used as a timing trigger or pulse shaper with any input signal shape from dc to 100 MHz. The discriminator circuit is dc coupled to render it free from any count rate effects, and is compatible with pulse shapes generated by any combination of scintillating phosphor and photomultiplier tube, including NaI (TI) and CsI(Tl). The discriminator is so designed as to provide only one output pulse for any input pulse width. The timing qualities of this unit are such that when used with a fast photomultiplier tube, even the best as of this date, such as the Philips XP-1021 or RCA 8575 tubes, and the best of plastic phosphors, i. e., Naton 136, the time dispersion is still limited by the phosphor characteristics and the photomultiplier tube. The unit provides two negative signals which are 14 mA on 50 ohms (0.7V), and are the so-called Type I logic pulses for use in fast timing circuitry, and one positive 5-volt, 500 nsec wide (Type II) pulse for such applications as scaler drivers and slow coincidence circuitry.

2. SPECIFICATIONS

Input:

Polarity: Negative
 Amplitude: 150 mV (min.), protected to $\pm 100V$ at 10% duty factor
 Impedance: 50 ohms $\pm 10\%$, dc ($< \pm 100V$ input)
 Width: 2 nsec to dc

Threshold Discriminator:

Range: 150 mV to 1V
 Linearity: Typically $< \pm 2\%$
 Drift with Temperature: ≤ 0.5 mV/ $^{\circ}C$ (0-50 $^{\circ}C$)
 Pulse Pair Resolution: ≤ 10 nsec (stretcher out)
 Count Rate: dc to 10^8 pulses/sec (stretcher out)
 Time Shift vs. Amplitude: ≤ 1.5 nsec from 2x-20x threshold (stretcher out)
 Propagation Delay: 9 nsec (nominal) for 2X threshold
 Delay Jitter: ≤ 15.0 psec fwhm (5.65 psec rms) for 2X threshold
 Delay Temperature Stability: ≤ 7 psec/ $^{\circ}C$

Outputs:

Fast Logic: (Terminate with 50 Ω when not in use)
 Polarity: Negative
 Number of Outputs: 2 each, completely isolated
 Amplitude: 14 mA, current drive, 0.7V on 50 ohms (limited at 1.2V)
 Width: 4 nsec nominal
 Rise Time: ≤ 2.5 nsec
 Fall Time: ≤ 3.0 nsec

Slow Logic:

Polarity: Positive
 Number of Outputs: One
 Amplitude: 5V, voltage drive
 Driving Impedance: ≤ 10 ohms
 Width: ~ 500 nsec
 Rise Time: ≤ 10 nsec

Power Required: +12V ~ 35 mA ~ -12V ~ 75 mA
 +24V ~ 25 mA ~ -24V ~ 50 mA

3. INSTALLATION INSTRUCTIONS

3.1 General

The 417 is used in conjunction with the 401/402 Bin and Power Supply, is intended for rack mounting, and therefore, it is necessary to ensure that vacuum tube equipment in the same rack has sufficient cooling air circulation to prevent any localized heating of the all-solid state circuitry used throughout the 417. The temperature of equipment mounted in racks can easily exceed the recommended maximum unless precautions are taken. The 417 should not be subjected to temperatures in excess of 120°F (50°C).

3.2 Connection to Power - Standard Nuclear Instrument Module, ORTEC 401/402

The 417 contains no power supply, and therefore must obtain power from an N.I.M. Bin and Power Supply, such as the ORTEC 401/402. It is recommended that the Bin power supply be turned off when inserting or removing modules. The ORTEC 400 Series is designed so that it is not possible to overload the Bin power supply with a full complement of modules in the Bin. However, this may not be true when the Bin contains modules other than those of ORTEC design. In this case, power supply voltages should be checked after the insertion of modules. The 401/402 has test points on the power supply control panel to monitor the dc voltages.

3.3 Connecting Into a System

The input and output connections to the 417 are via front panel BNC connectors. When the unit is used in a timing setup utilizing photomultiplier tubes, the input signal should be transported from the anode of the PM to the input of the 417 via good quality 50Ω coaxial cable, e.g., RG-8/U. If the transport distance is short, lesser quality cable, such as RG-58/U, is permissible.

To explain these statements, a short discussion of coaxial cables is in order. Pulses transmitted through coaxial cables suffer both attenuation and distortion. In most cables commonly used for pulse work, skin effect losses in the conductor are the predominant losses for frequency components below approximately 1000 MHz. Skin effect losses result in high-frequency attenuation which, expressed in decibels, increases as ω^2 . An ideal step-function pulse impressed on the line appears at the (matched) far end with the shape shown in Figure 1.

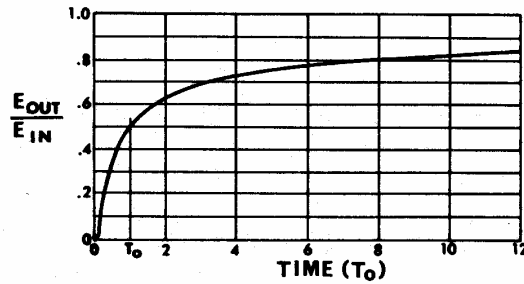

Figure 1. Step-function response of transmission lines for which decibel attenuation varies as the square root of frequency. The time T_0 is defined as the interval measured from the start of the output pulse to the point at which $E_{OUT} = 0.5 E_{IN}$.

The rise time from 0 to X per cent can be expressed as multiples of T_0 , where T_0 is the 0 to 50 per cent rise time. Table 1 presents some rise time conversion factors.

TABLE 1. RISE TIME CONVERSION FACTORS

Percent of Pulse Height	0 to X% Rise Time	
10	T_0	0.17
20		0.28
50		1.0
70		3.1
80		7.3
90		29.0
95		110.0

10% to 90% rise time = $(29.0 - 0.17) T_0 = 28.83 T_0$

In Figure 2, T_0 is plotted against the delay length in nanoseconds.

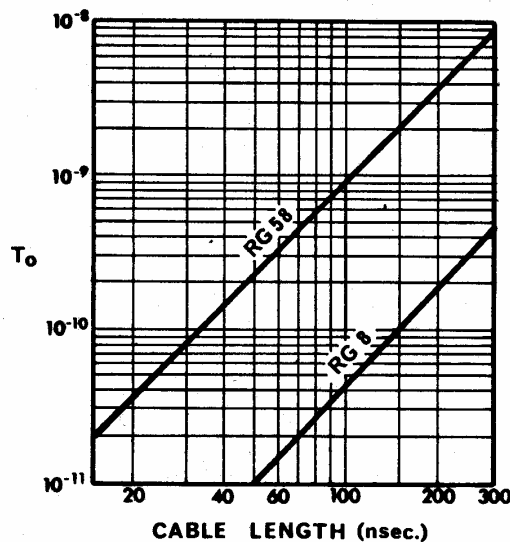

Figure 2. Calculated variation of T_0 with cable length for RG-58A/U, and RG-8/U

For RG-58/U cable whose decibel attenuation varies as $\omega^{\frac{1}{2}}$ for frequencies between about 100 MHz and 1000 MHz, it is convenient to calculate T_o by:

$$T_o = 3.0 \times 10^{-16} A^2 l^2 \text{ seconds}$$

where A is the commonly tabulated attenuation at 1000 MHz expressed in db/100 feet (8.0 to 9.0 for RG/8U and 20 to 24 for RG-58A/U), and l is the length in nanoseconds.

Since the rise time is proportional to the square of length, if two equal lengths of a given type of cable are cascaded, the rise time of the combination is four times the rise time of either length alone. This is in contrast to the familiar case of amplifiers of Gaussian frequency response, in which the rise time varies as the square root of the number of identical sections. For this reason, and also because the characteristic step-function responses of cables and of Gaussian devices are so different, the over-all rise time of combinations cannot be calculated from the square root of the sum of squares of individual rise times, either with cables alone or where cables are combined with Gaussian elements. Instead, the over-all response of a system with cables and other elements may be obtained graphically or with convolution integrals, using either step or impulse (obtained from the derivative of the function plotted in Fig. 1) function responses.

Coupling from the output of the 417 to other equipment such as fast coincidence units or time-to-pulse-height converters, may be performed with poor quality cable without timing degradation, because the output signal has been standardized in both amplitude and width. The only requirement is that the input circuit which is driven have a stable triggering threshold.

4. OPERATING INSTRUCTIONS

4.1 Front Panel Controls

The 417 has two front panel controls, which are the Discriminator Level control and the Stretcher Selector switch. The Discriminator Level control sets a dc bias on the discriminator element (a tunnel diode) which determines at what level of input voltage the unit will trigger. The dial is normalized to the low end reading or 150 mV. The discriminator dial versus input voltage curve is essentially linear, but the slope may vary by as much as 10%. This means that 150 dial divisions are equal to 150 mV, but 1000 dial divisions equals 1V only to approximately $\pm 10\%$.

The Stretcher Selector switch selects whether the input pulse is stretched or not. When used with a PM tube and plastic phosphor, the switch should be set to the "OUT" position. This ensures maximum count rate capability. When used with a phosphor such as NaI (TI) or CsI (TI), the switch should be set to the "IN" position. This inserts a stretcher, which is discharged at a constant rate, into the input circuitry. The stretcher creates a monotonically decreasing signal from these signal types.

When using the 417 with a PM setup, it is advisable to view the linear output of the PM-amplifier complex with an oscilloscope that is triggered from the output of the 417 which is being adjusted. This will ensure correct setting of the discriminator level with respect to the input signal.

4.2 Timing with Photomultipliers

Timing with photomultipliers implies some type of coincidence measurement. This measurement may be performed with standard coincidence circuits such as pulse overlap type which are essentially single channel time analyzers, or with time-to-pulse height converters which are differential, or multichannel time analyzers.

The response of the coincidence system to a prompt cascade always has finite width which comes from a variety of sources. The most important of these are as follows:

1. Variation of time of interaction of radiation with the scintillator and the amount of energy deposited therein.
2. Finite decay time of light emitting states in the phosphor and variation of times of photon arrival at the multiplier cathode.
3. Variation of transit time of photoelectrons in the photomultiplier due to a) different path lengths, and b) variation of initial energy and angle of the secondary electrons.
4. Jitter and uncertainties of times of triggering of the associated electronics.

The variation in the time of interaction can be minimized by appropriate geometry and small scintillators at a corresponding loss in efficiency and average energy deposition.

For a complete discussion of timing with photomultipliers, the reader is referred to some of the excellent literature available on the subject.^{1, 2, 3}

- 1 A. Schwarzschild, Nucl. Instr. Meth. 21: 1-16 (1963)
- 2 G. Present, et al., Nucl. Instr. Meth. 31(1): 71-6 (1964)
- 3 E. Gatti and V. Svelto, Nucl. Instr. Meth. 30: 213-23 (1964)
- 4 R. L. Graham, et al., IEEE Trans. on Nucl. Sci. NS-13(1): 72 (Feb. 1966)

4.3 Applications

The different specific applications for the 417 are essentially limitless, but since the unit was designed primarily for timing with photomultipliers, a number of system block diagrams for this type of usage are given. Some typical resolution curves for three of the systems will be given separately, from which operational characteristics of other systems may be implied.

4.3.1 Typical Fast-Slow Coincidence System Using Plastic Scintillators

Figure 3 is a block diagram of a system which one might use to perform lifetime measurements or to study the time dispersion associated with some prescribed coincidence events. It does not represent an optimum system if one requires clean slopes of the coincidence curves to four or five decades, but will give clean spectra to at least three decades at moderately high count rates. The time spectrum shown in Figure 4 represents what may easily be obtained under lab conditions using the 417 and other appropriate equipment. It is important to remember that the resolution obtainable varies as $1/\sqrt{n}$, where n represents the number of photoelectrons created by the event, and is therefore representative of the amount of energy deposited in the scintillating phosphor.

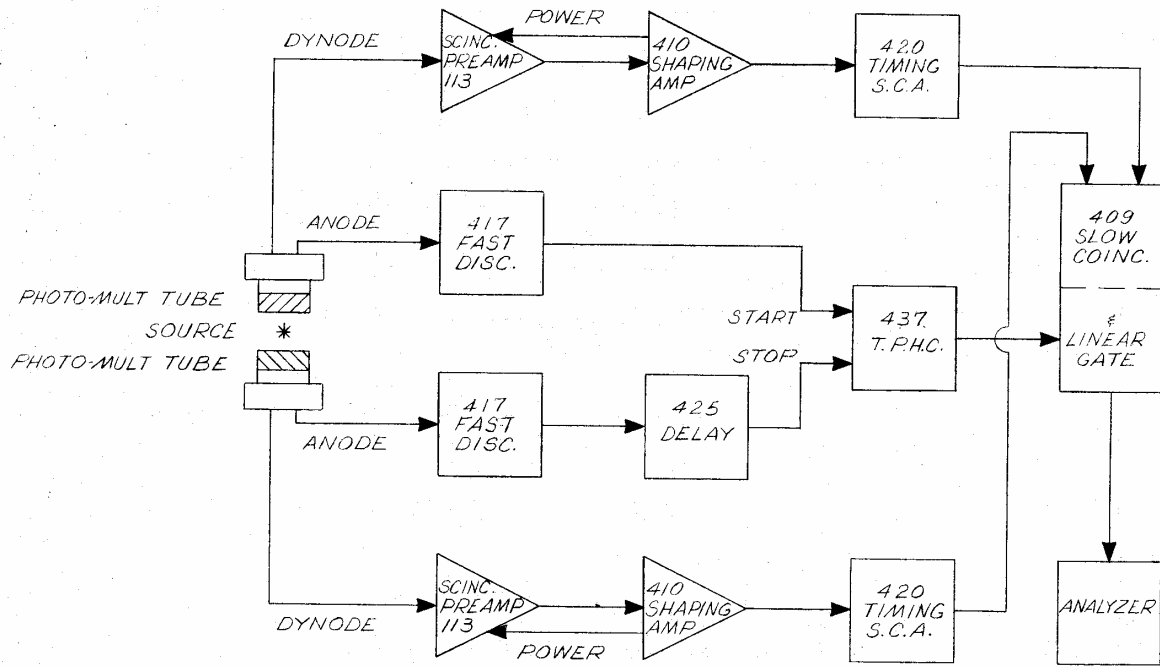

Figure 3. Simple Fast-Slow Coincidence System

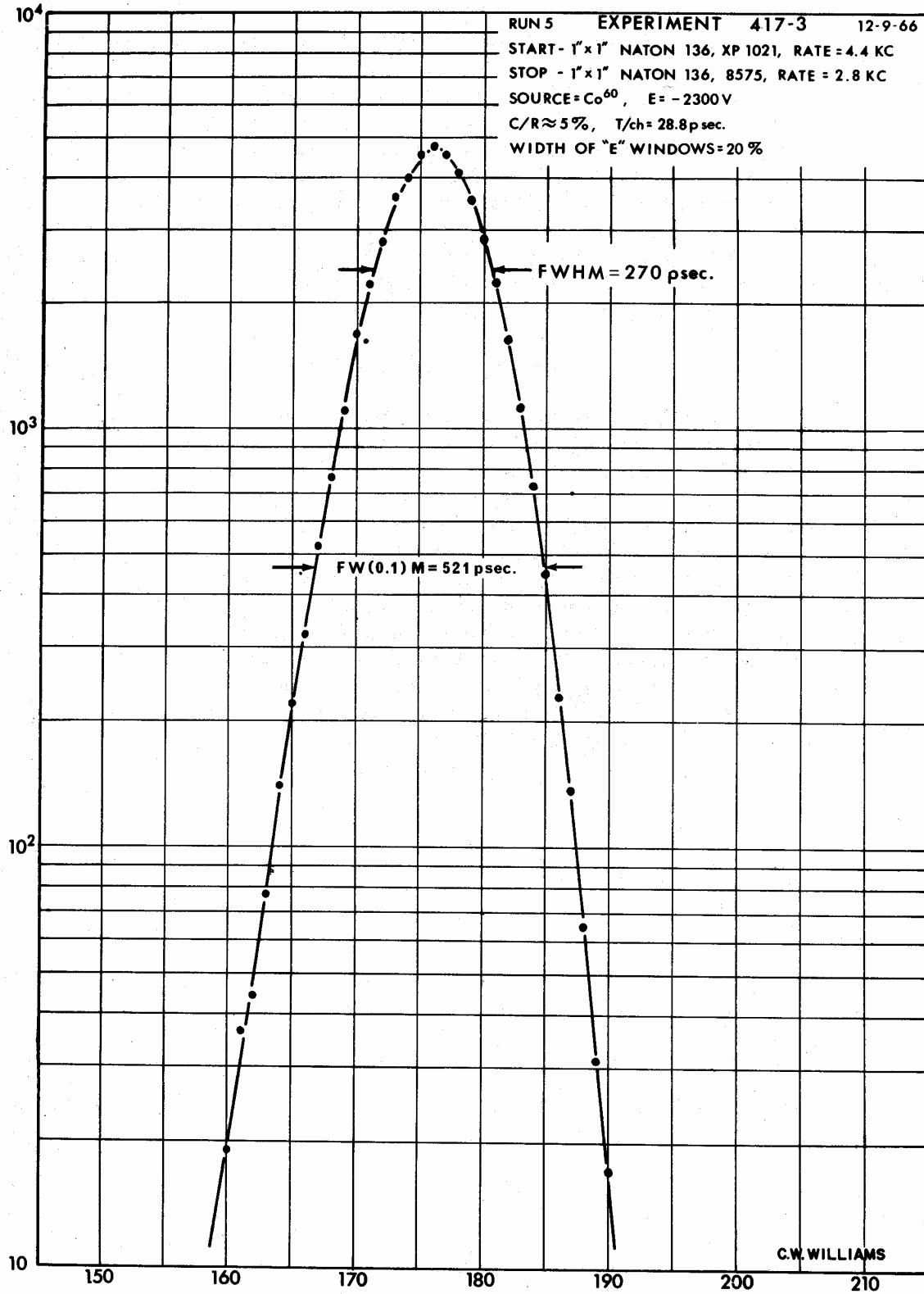

Figure 4. A Typical Coincidence Spectrum Using Plastic Scintillators

4.3.2 Typical Fast-Slow Coincidence Using NaI (TI)

The block diagram of Figure 3 applies equally well here. The difference in the two systems is the scintillator and its decay characteristic. This decay time constant is $0.25\mu\text{sec}$, whereas the same time constant for NaI 136 is approximately 2 nsec. With NaI (TI) much more total light is produced per equivalent energy event, but the collection of this light is over such a wide period of time, as indicated, that the time resolution is poorer than that of plastic. Figure 5 (page 4-6) is a typical spectrum taken with a $1\frac{1}{2}'' \times 1''$ NaI (TI) on one side of the coincidence system.

4.3.3 Fast Coincidence Using Ge (Li-drift) Detectors

Some recent experiments have been performed using a $1\frac{1}{2}'' \times 1''$ NaI (TI) in a $\gamma-\gamma$ coincidence arrangement with an ORTEC 10cm^3 Ge (Li-drift) coaxial detector, as shown in Figure 6. In this case, the radiant energy from the source was not collimated at all, so that the time is given by collection from all parts of the detector. The source viewed one end of the germanium detector. Side channels selected the energy region of interest, which was the photopeak on each side. The full time spectrum is given in Figure 7 (page 4-7). Full width at half maximum and full width at one-tenth maximum are indicated. This, when compared with published timing curves⁴, indicates a far superior detector design for timing purposes. The efficiencies associated with the FWHM and the FW (0.1) max points are 60% and 92% respectively.

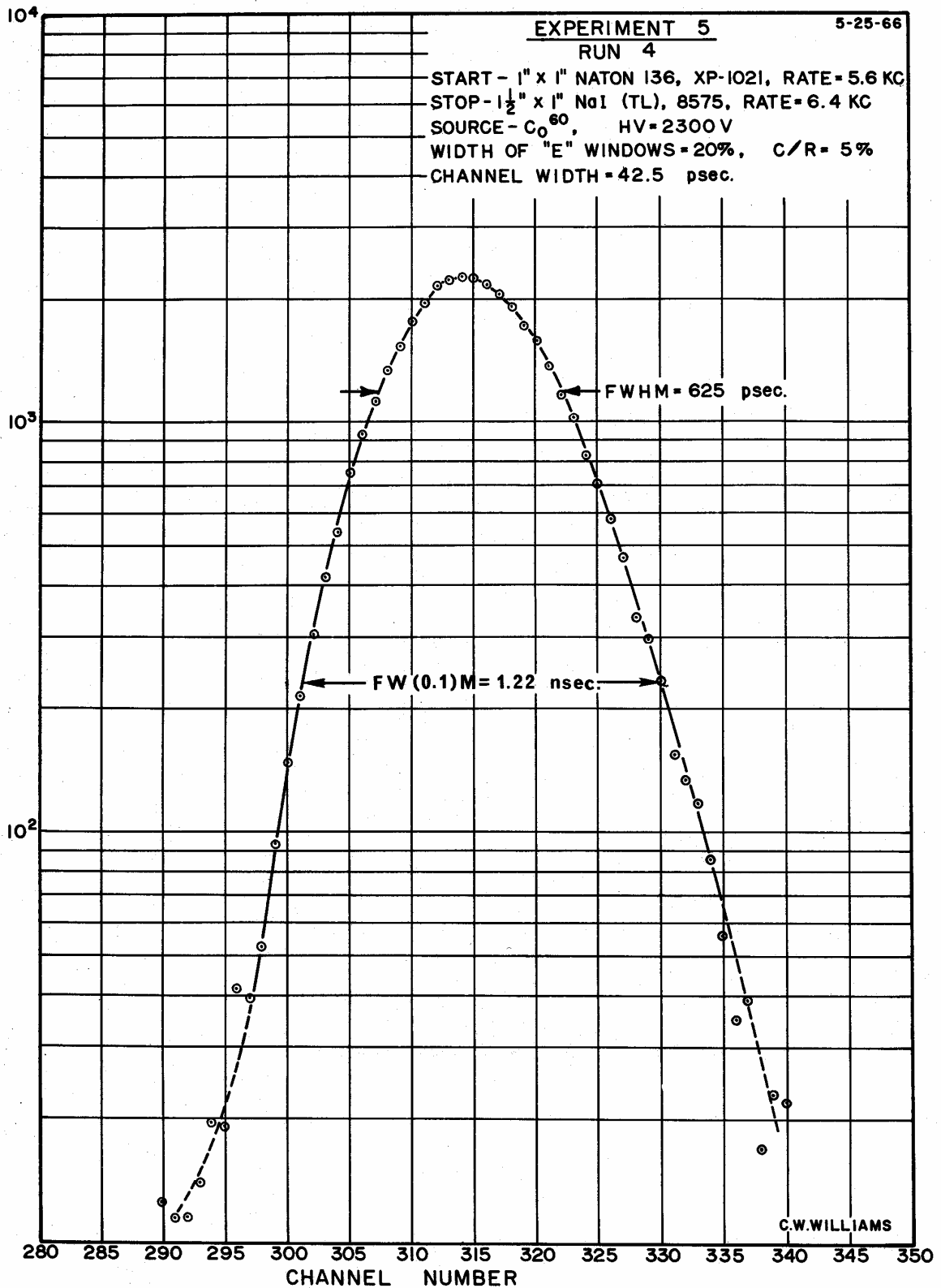

Figure 5. A Typical Coincidence Spectrum Using NaI (TI) Scintillator

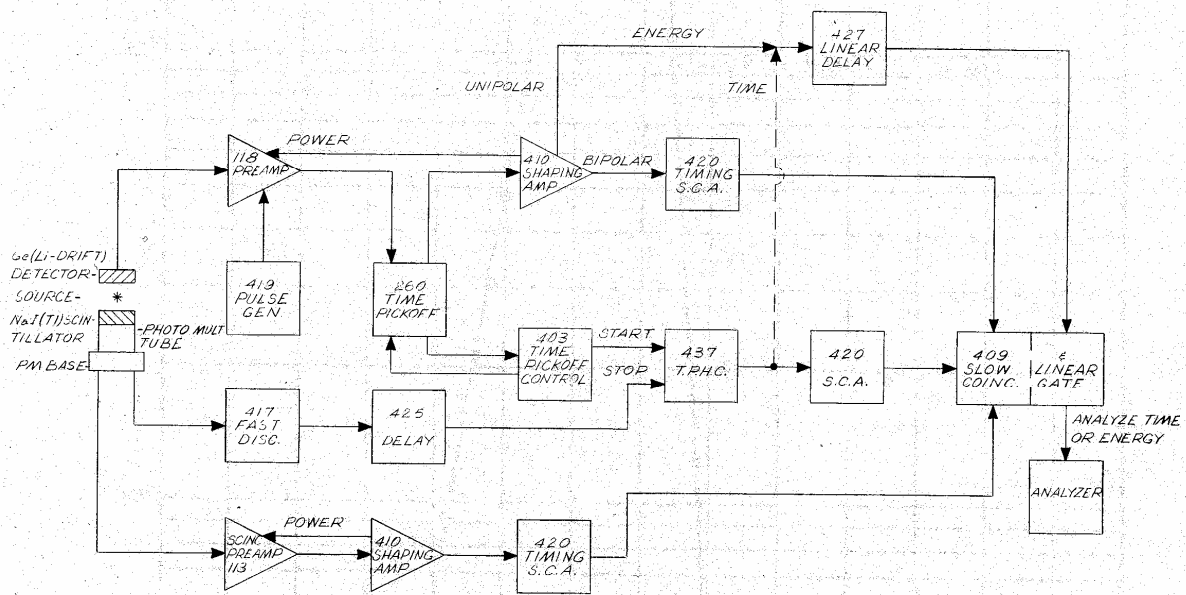

Figure 6. Gamma-gamma Coincidence System With a Ge (Li-drifted) Detector

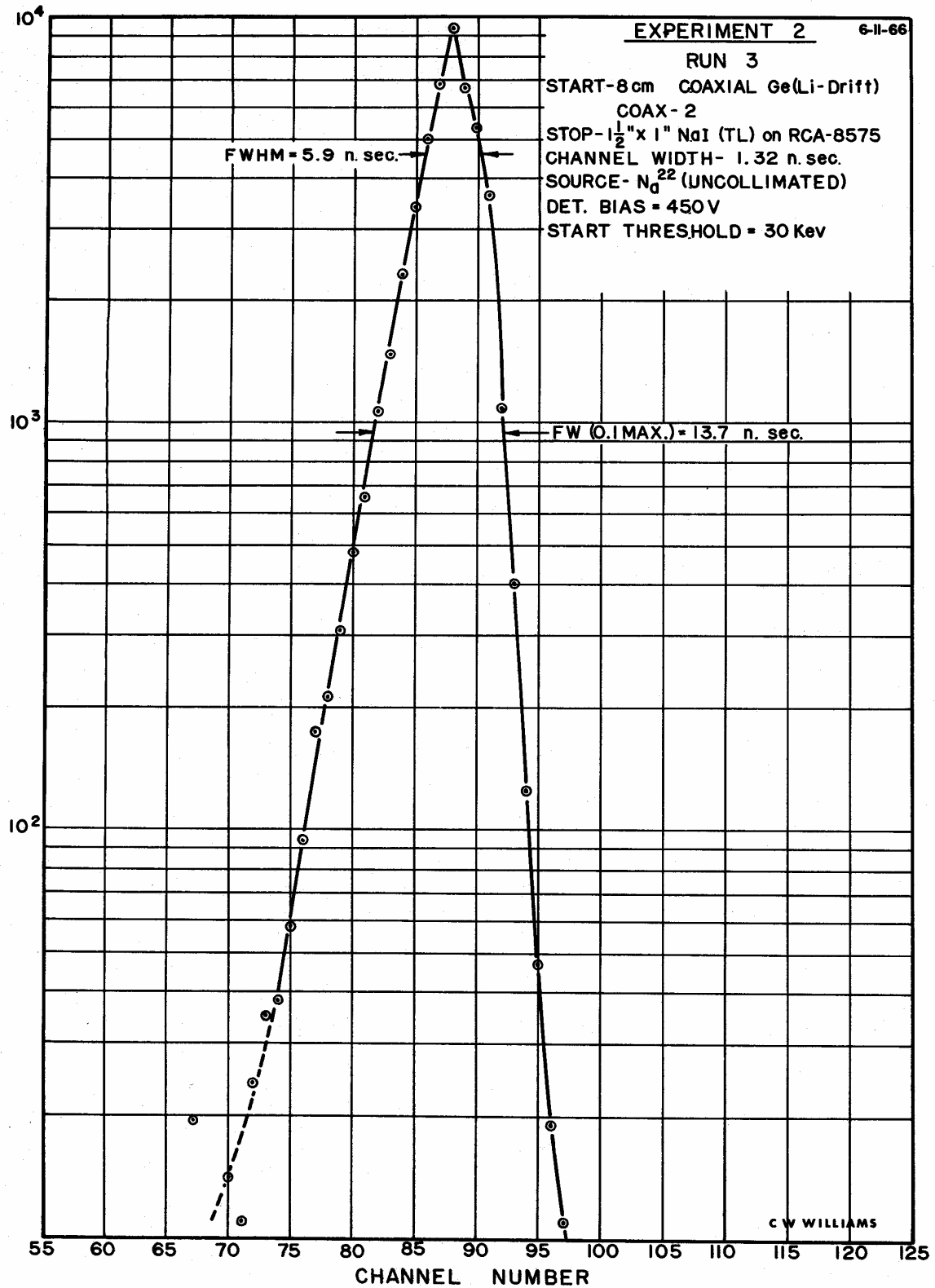
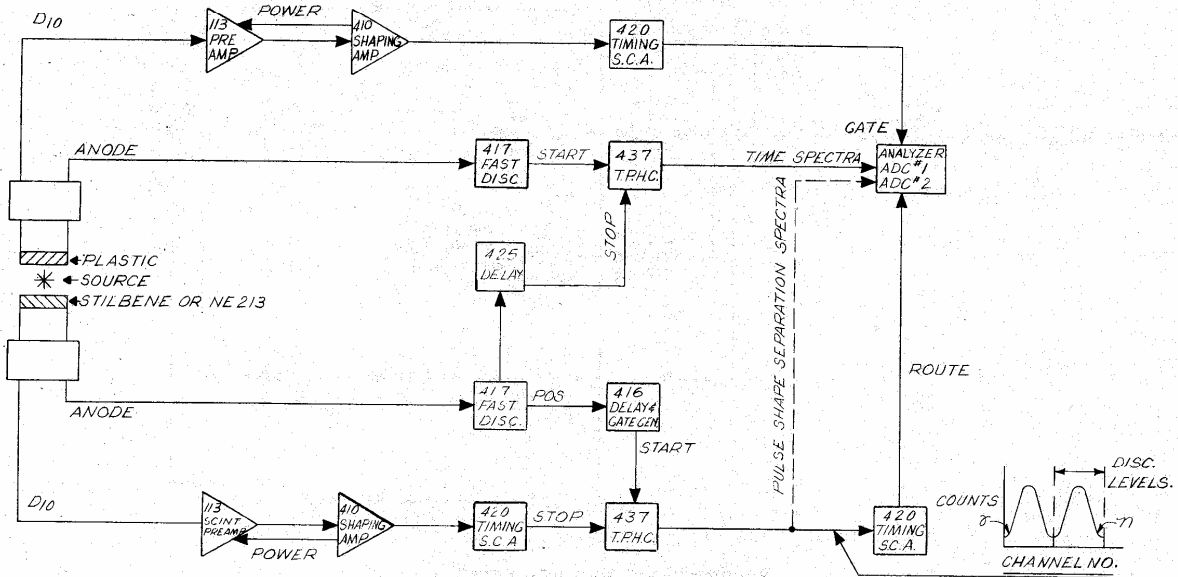

Figure 7. Timing Spectrum With Ge (Li-drifted) Detector

4.3.4 System Block Diagrams

A number of experimental systems are shown in the enclosed block diagrams for the aid of the user.



Fast-Fast Coincidence (PMT) With Pulse Shape Discrimination

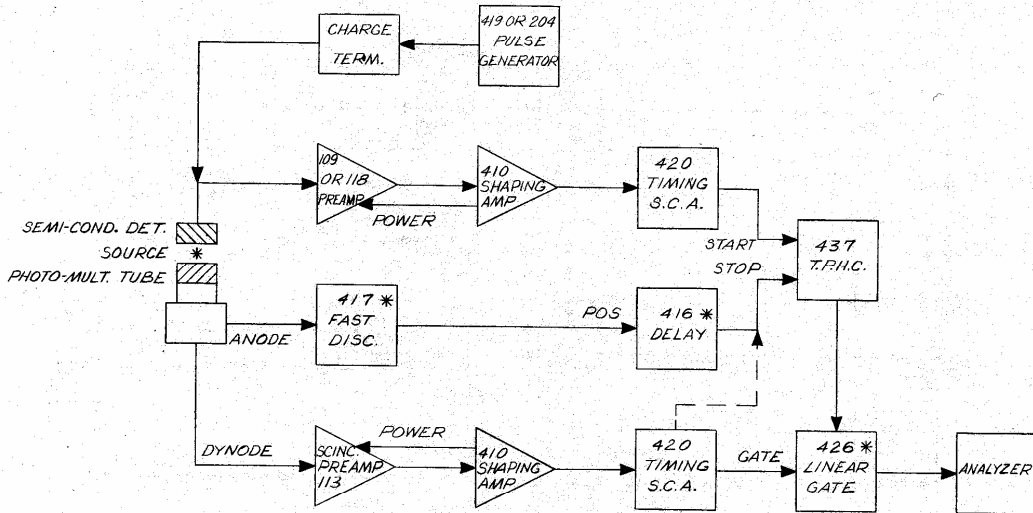

* OPTIONAL - NOT NEEDED IF CROSSOVER TIMING IS CHOSEN.

Fast Timing for (Semi-conductor Detector PMT) Coincidence Using Crossover Pickoff Technique

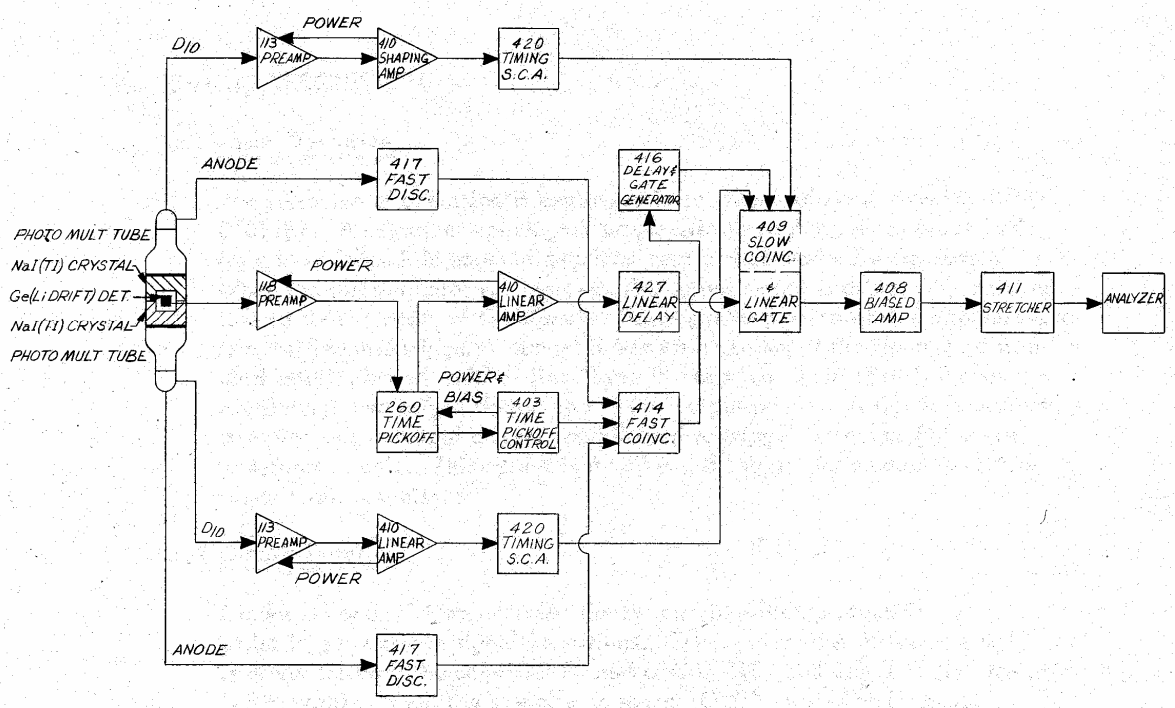

Gamma Ray Pair Spectrometer

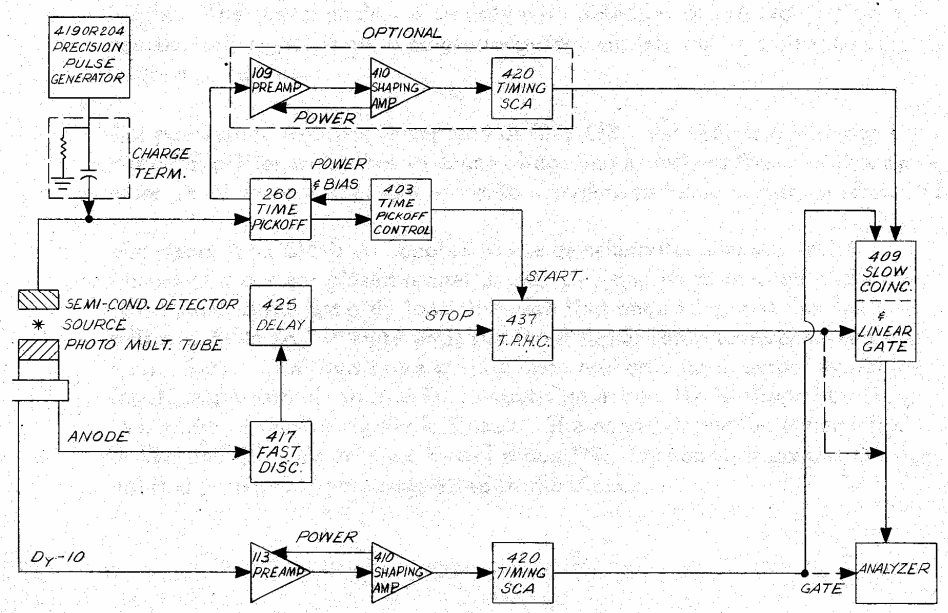

Sub-Nano Second Timing System (Semi-Conductor - Photo Multiplier Tube)

5. CIRCUIT DESCRIPTION

5.1 Basic Operation

The sequence of operation is explained in the block diagram drawing 417-0101-B1. A negative input signal propagates through an input diode limiter and wideband dc coupled amplifier to a tunnel diode discriminator. When the discriminator is triggered, the output signal is clipped by a delay line to fix the width of the signal. The negative portion of this clipped signal is amplified and triggers a tunnel diode which reshapes the signal to a standard amplitude and width. This "Type I" negative signal then is fanned out through two output drivers to the fast output points. A signal is derived from one of the output drivers, and is used to trigger a slow output pulse generator circuit. This output is the "Type II" signal for medium and slow speed logic operations.

5.2 Circuit Detail

Diodes D1 and D2 form an input limiter circuit which protects the unit under large overload signal conditions. Q1 is an emitter follower which is driver for both the amplifier formed of Q2, Q3, and Q5, and the stretcher (when used). When the stretcher is set to "OUT", the stretch capacitor C4 is removed from the circuit and the idle current is increased. With the stretcher switched to "IN" the capacitor C4 is charged to the amplitude of a negative input signal and is discharged with a constant current of approximately 1 mA. This makes the stretch period proportional to pulse height. The stretcher should be used with detectors of the NaI (TI) type because this signal is not a single long-term signal, but is a burst of very short-term signals.

The dc coupled amplifier composed of Q2, Q3, and Q5, is a wideband biased amplifier which has its bias voltage input derived from the Discriminator Level control R22. Q4 serves to compensate for temperature effects of Q1.

The signal from Q5 is dc coupled to the discriminator element which is formed of a current biased tunnel diode, D7, and its associated circuitry. This tunnel diode has a dc load line such that once triggered the diode will remain in its "1" state until the input signal returns to approximately zero. This assures that there will be one, and only one, output signal per input, regardless of width. The output signal from D7 is clipped by DL-1 to a width of approximately 3.5 nsec. The negative portion is amplified by Q6 and Q7, and triggers tunnel diode D9. D9 merely reshapes the signal and prepares it for transmitting to the output.

The signal from D9 feeds two identical output stages in parallel. These are formed of Q8-9-10 and Q12-13-14. Only one output stage is described. Q8 is an emitter follower buffer for the current switch output driver pair Q9 and Q10. The output signal is limited at approximately 1.2V by D10 and R46 when the 50-ohm output termination is removed. The circuit may be operated without terminations on the unused outputs; however, it is recommended that the negative signals be terminated even when not in use.

A signal is derived from the collector of Q13, which triggers the positive signal output pair, Q15-Q16. In steady state, the collector current of Q16 holds the emitter follower Q17 in the off condition. When the circuit is triggered, the pulse width is determined by C18, R74, and R60, and the output amplitude is determined by the voltage divider R73 and 75.

ORTEC[®]

INSTRUCTION MANUAL MODEL 417 FAST DISCRIMINATOR

Serial No. _____

Purchaser _____

Date Issued _____

NSCL-ELECTR

ORTEC Incorporated
P.O. BOX C
OAK RIDGE, TENNESSEE 37830
Telephone (615) 483-8451
TWX 810-572-1078

TABLE OF CONTENTS

	Page
WARRANTY	
PHOTOGRAPH	
1. DESCRIPTION	1-1
2. SPECIFICATIONS	2-1
3. INSTALLATION INSTRUCTIONS	3-1
3.1 General	3-1
3.2 Connection to Power — Standard Nuclear Instrument Module, ORTEC 401/402	3-1
3.3 Connecting Into a System	3-1
4. OPERATING INSTRUCTIONS	4-1
4.1 Front Panel Controls	4-1
4.2 Timing with Photomultipliers	4-1
4.3 Applications	4-2
5. CIRCUIT DESCRIPTION	5-1
5.1 Basic Operation	5-1
5.2 Circuit Detail	5-1
6. MAINTENANCE	6-1
6.1 Testing Performance	6-1
6.2 Tabulated Test Point Voltages	6-2
6.3 Factory Service	6-2
7. BIN/MODULE CONNECTOR PIN ASSIGNMENTS FOR AEC STANDARD NUCLEAR INSTRUMENT MODULES	7-1
Block Diagram and Schematic	
417-0101-B2	ORTEC 417 Block Diagram
417-0101-S2	ORTEC 417 Fast Discriminator

LIST OF FIGURES AND ILLUSTRATIONS

	Page
1. Step-Function Response of Transmission Line for Which Decibel Attenuation Varies as the Square Root of Frequency	3-2
2. Calculated Variation of T_0 with Cable Length for RG-58A/U, and RG-8/U	3-2
3. Simple Fast Slow Coincidence System	4-3
4. A Typical Coincidence Spectrum Using Plastic Scintillators	4-4
5. A Typical Coincidence Spectrum Using NaI (TI) Scintillator	4-6
6. Gamma-gamma Coincidence System With a Ge (Li-drifted) Detector	4-7
7. Timing Spectrum With Ge (Li-drifted) Detector	4-8

Typical System Block Diagrams

Fast-Fast Coincidence (PMT) With Pulse Shape Discrimination	4-9
Fast Timing for (Semi-conductor Detector PMT) Coincidence Using Crossover Pickoff Technique	4-9
Gamma Ray Pair Spectrometer	4-10
Sub-Nano Second Timing System (Semi-Conductor-Photo Multiplier Tube)	4-10

STANDARD WARRANTY FOR ORTEC ELECTRONIC INSTRUMENTS

DAMAGE IN TRANSIT

Shipments should be examined immediately upon receipt for evidence of external or concealed damage. The carrier making delivery should be notified immediately of any such damage, since the carrier is normally liable for damage in shipment. Packing materials, waybills, and other such documentation should be preserved in order to establish claims. After such notification to the carrier, notify ORTEC of the circumstances so that we may assist in damage claims and in providing replacement equipment when necessary.

WARRANTY

ORTEC warrants its electronic products to be free from defects in workmanship and materials, other than vacuum tubes and semiconductors, for a period of twelve months from date of shipment, provided that the equipment has been used in a proper manner and not subjected to abuse. Repairs or replacement, at ORTEC option, will be made without charge at the ORTEC factory. Shipping expense will be to the account of the customer except in cases of defects discovered upon initial operation. Warranties of vacuum tubes and semiconductors, as made by their manufacturers, will be extended to our customers only to the extent of the manufacturers' liability to ORTEC. Specially selected vacuum tubes or semiconductors cannot be warranted. ORTEC reserves the right to modify the design of its products without incurring responsibility for modification of previously manufactured units. Since installation conditions are beyond our control, ORTEC does not assume any risks or liabilities associated with the methods of installation, or installation results.

QUALITY CONTROL

Before being approved for shipment, each ORTEC instrument must pass a stringent set of quality control tests designed to expose any flaws in materials or workmanship. Permanent records of these tests are maintained for use in warranty repair and as a source of statistical information for design improvements.

REPAIR SERVICE

ORTEC instruments not in warranty may be returned to the factory for repairs or checkout at modest expense to the customer. Standard procedure requires that returned instruments pass the same quality control tests as those used for new production instruments. Please contact the factory for instructions before shipping equipment.

ORTEC[®]

MODEL 417

**FAST
DISCRIMINATOR**

DISC. LEVEL



STRETCHER
IN



OUT



INPUT

NEG.

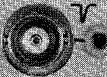

OUTPUT 1

NEG.

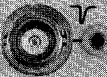

OUTPUT 2

POS.



OUTPUT 3

+12V 35mA
-12V 75mA
+24V 25mA
-24V 50mA



MODEL 417 FAST DISCRIMINATOR

1. DESCRIPTION

The 417 Fast Discriminator is designed as a time derivation unit, primarily for use with photomultiplier tubes, but versatile enough to be used as a timing trigger or pulse shaper with any input signal shape from dc to 100 MHz. The discriminator circuit is dc coupled to render it free from any count rate effects, and is compatible with pulse shapes generated by any combination of scintillating phosphor and photomultiplier tube, including NaI (TI) and CsI(Tl). The discriminator is so designed as to provide only one output pulse for any input pulse width. The timing qualities of this unit are such that when used with a fast photomultiplier tube, even the best as of this date, such as the Philips XP-1021 or RCA 8575 tubes, and the best of plastic phosphors, i.e., Naton 136, the time dispersion is still limited by the phosphor characteristics and the photomultiplier tube. The unit provides two negative signals which are 14 mA on 50 ohms (0.7V), and are the so-called Type I logic pulses for use in fast timing circuitry, and one positive 5-volt, 500 nsec wide (Type II) pulse for such applications as scaler drivers and slow coincidence circuitry.

2. SPECIFICATIONS

Input:

Polarity: Negative

Amplitude: 150 mV (min.), protected to $\pm 100V$ at 10% duty factor

Impedance: 50 ohms $\pm 10\%$, dc ($< \pm 100V$ input)

Width: 2 nsec to dc

Threshold Discriminator:

Range: 150 mV to 1V

Linearity: Typically $< \pm 2\%$

Drift with Temperature: ≤ 0.5 mV/ $^{\circ}C$ (0-50 $^{\circ}C$)

Pulse Pair Resolution: ≤ 10 nsec (stretcher out)

Count Rate: dc to 10^8 pulses/sec (stretcher out)

Time Shift vs. Amplitude: ≤ 1.5 nsec from 2x-20x threshold (stretcher out)

Propagation Delay: 9 nsec (nominal) for 2X threshold

Delay Jitter: ≤ 15.0 psec fwhm (5.65 psec rms) for 2X threshold

Delay Temperature Stability: ≤ 7 psec/ $^{\circ}C$

Outputs:

Fast Logic: (Terminate with 50 Ω when not in use)

Polarity: Negative

Number of Outputs: 2 each, completely isolated

Amplitude: 14 mA, current drive, 0.7V on 50 ohms (limited at 1.2V)

Width: 4 nsec nominal

Rise Time: ≤ 2.5 nsec

Fall Time: ≤ 3.0 nsec

Slow Logic:

Polarity: Positive

Number of Outputs: One

Amplitude: 5V, voltage drive

Driving Impedance: ≤ 10 ohms

Width: ~ 500 nsec

Rise Time: ≤ 10 nsec

Power Required:	+12V	~ 35 mA	$\sim -12V$	~ 75 mA
	+24V	~ 25 mA	$\sim -24V$	~ 50 mA

3. INSTALLATION INSTRUCTIONS

3.1 General

The 417 is used in conjunction with the 401/402 Bin and Power Supply, is intended for rack mounting, and therefore, it is necessary to ensure that vacuum tube equipment in the same rack has sufficient cooling air circulation to prevent any localized heating of the all-solid state circuitry used throughout the 417. The temperature of equipment mounted in racks can easily exceed the recommended maximum unless precautions are taken. The 417 should not be subjected to temperatures in excess of 120°F (50°C).

3.2 Connection to Power - Standard Nuclear Instrument Module, ORTEC 401/402

The 417 contains no power supply, and therefore must obtain power from an N.I.M. Bin and Power Supply, such as the ORTEC 401/402. It is recommended that the Bin power supply be turned off when inserting or removing modules. The ORTEC 400 Series is designed so that it is not possible to overload the Bin power supply with a full complement of modules in the Bin. However, this may not be true when the Bin contains modules other than those of ORTEC design. In this case, power supply voltages should be checked after the insertion of modules. The 401/402 has test points on the power supply control panel to monitor the dc voltages.

3.3 Connecting Into a System

The input and output connections to the 417 are via front panel BNC connectors. When the unit is used in a timing setup utilizing photomultiplier tubes, the input signal should be transported from the anode of the PM to the input of the 417 via good quality 50 Ω coaxial cable, e.g., RG-8/U. If the transport distance is short, lesser quality cable, such as RG-58/U, is permissible.

To explain these statements, a short discussion of coaxial cables is in order. Pulses transmitted through coaxial cables suffer both attenuation and distortion. In most cables commonly used for pulse work, skin effect losses in the conductor are the predominant losses for frequency components below approximately 1000 MHz. Skin effect losses result in high-frequency attenuation which, expressed in decibels, increases as $\omega^{\frac{1}{2}}$. An ideal step-function pulse impressed on the line appears at the (matched) far end with the shape shown in Figure 1.

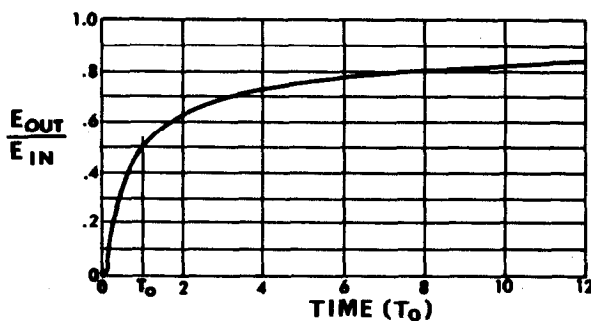

Figure 1. Step-function response of transmission lines for which decibel attenuation varies as the square root of frequency. The time T_0 is defined as the interval measured from the start of the output pulse to the point at which $E_{out} = 0.5 E_{in}$.

The rise time from 0 to X per cent can be expressed as multiples of T_0 , where T_0 is the 0 to 50 per cent rise time. Table 1 presents some rise time conversion factors.

TABLE 1. RISE TIME CONVERSION FACTORS

Percent of Pulse Height	0 to X% Rise Time	
10	T_0	0.17
20		0.28
50		1.0
70		3.1
80		7.3
90		29.0
95		110.0

$$10\% \text{ to } 90\% \text{ rise time} = (29.0 - 0.17) T_0 = 28.83 T_0$$

In Figure 2, T_0 is plotted against the delay length in nanoseconds.

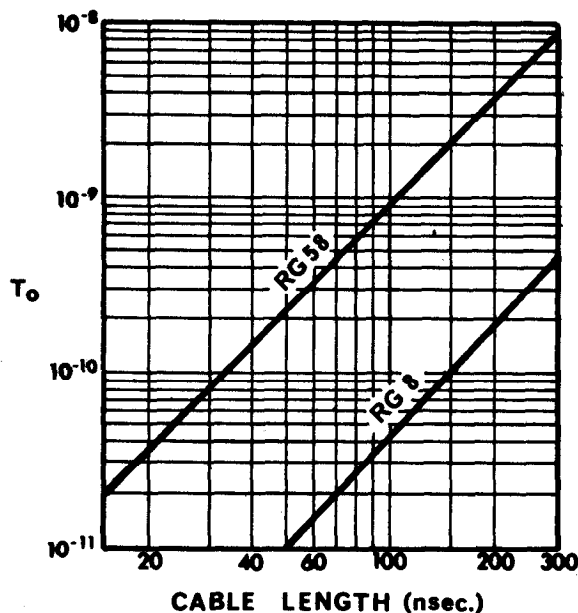

Figure 2. Calculated variation of T_0 with cable length for RG-58A/U, and RG-8/U

For RG-58/U cable whose decibel attenuation varies as $\omega^{\frac{1}{2}}$ for frequencies between about 100 MHz and 1000 MHz, it is convenient to calculate T_0 by:

$$T_0 = 3.0 \times 10^{-16} A^2 l^2 \text{ seconds}$$

where A is the commonly tabulated attenuation at 1000 MHz expressed in db/100 feet (8.0 to 9.0 for RG/8U and 20 to 24 for RG-58A/U), and l is the length in nanoseconds.

Since the rise time is proportional to the square of length, if two equal lengths of a given type of cable are cascaded, the rise time of the combination is four times the rise time of either length alone. This is in contrast to the familiar case of amplifiers of Gaussian frequency response, in which the rise time varies as the square root of the number of identical sections. For this reason, and also because the characteristic step-function responses of cables and of Gaussian devices are so different, the over-all rise time of combinations cannot be calculated from the square root of the sum of squares of individual rise times, either with cables alone or where cables are combined with Gaussian elements. Instead, the over-all response of a system with cables and other elements may be obtained graphically or with convolution integrals, using either step or impulse (obtained from the derivative of the function plotted in Fig. 1) function responses.

Coupling from the output of the 417 to other equipment such as fast coincidence units or time-to-pulse-height converters, may be performed with poor quality cable without timing degradation, because the output signal has been standardized in both amplitude and width. The only requirement is that the input circuit which is driven have a stable triggering threshold.

4. OPERATING INSTRUCTIONS

4.1 Front Panel Controls

The 417 has two front panel controls, which are the Discriminator Level control and the Stretcher Selector switch. The Discriminator Level control sets a dc bias on the discriminator element (a tunnel diode) which determines at what level of input voltage the unit will trigger. The dial is normalized to the low end reading or 150 mV. The discriminator dial versus input voltage curve is essentially linear, but the slope may vary by as much as 10%. This means that 150 dial divisions are equal to 150 mV, but 1000 dial divisions equals 1V only to approximately $\pm 10\%$.

The Stretcher Selector switch selects whether the input pulse is stretched or not. When used with a PM tube and plastic phosphor, the switch should be set to the "OUT" position. This ensures maximum count rate capability. When used with a phosphor such as NaI (TI) or CsI (TI), the switch should be set to the "IN" position. This inserts a stretcher, which is discharged at a constant rate, into the input circuitry. The stretcher creates a monotonically decreasing signal from these signal types.

When using the 417 with a PM setup, it is advisable to view the linear output of the PM-amplifier complex with an oscilloscope that is triggered from the output of the 417 which is being adjusted. This will ensure correct setting of the discriminator level with respect to the input signal.

4.2 Timing with Photomultipliers

Timing with photomultipliers implies some type of coincidence measurement. This measurement may be performed with standard coincidence circuits such as pulse overlap type which are essentially single channel time analyzers, or with time-to-pulse height converters which are differential, or multichannel time analyzers.

The response of the coincidence system to a prompt cascade always has finite width which comes from a variety of sources. The most important of these are as follows:

1. Variation of time of interaction of radiation with the scintillator and the amount of energy deposited therein.
2. Finite decay time of light emitting states in the phosphor and variation of times of photon arrival at the multiplier cathode.
3. Variation of transit time of photoelectrons in the photomultiplier due to a) different path lengths, and b) variation of initial energy and angle of the secondary electrons.
4. Jitter and uncertainties of times of triggering of the associated electronics

The variation in the time of interaction can be minimized by appropriate geometry and small scintillators at a corresponding loss in efficiency and average energy deposition.

For a complete discussion of timing with photomultipliers, the reader is referred to some of the excellent literature available on the subject.^{1,2,3}

- 1 A. Schwarzschild, Nucl. Instr. Meth. 21: 1-16 (1963)
- 2 G. Present, et al., Nucl. Instr. Meth. 31(1): 71-6 (1964)
- 3 E. Gatti and V. Svelto, Nucl. Instr. Meth. 30: 213-23 (1964)
- 4 R. L. Graham, et al., IEEE Trans. on Nucl. Sci. NS-13(1): 72 (Feb. 1966)

4.3 Applications

The different specific applications for the 417 are essentially limitless, but since the unit was designed primarily for timing with photomultipliers, a number of system block diagrams for this type of usage are given. Some typical resolution curves for three of the systems will be given separately, from which operational characteristics of other systems may be implied.

4.3.1 Typical Fast-Slow Coincidence System Using Plastic Scintillators

Figure 3 is a block diagram of a system which one might use to perform lifetime measurements or to study the time dispersion associated with some prescribed coincidence events. It does not represent an optimum system if one requires clean slopes of the coincidence curves to four or five decades, but will give clean spectra to at least three decades at moderately high count rates. The time spectrum shown in Figure 4 represents what may easily be obtained under lab conditions using the 417 and other appropriate equipment. It is important to remember that the resolution obtainable varies as $1/\sqrt{n}$, where n represents the number of photoelectrons created by the event, and is therefore representative of the amount of energy deposited in the scintillating phosphor.

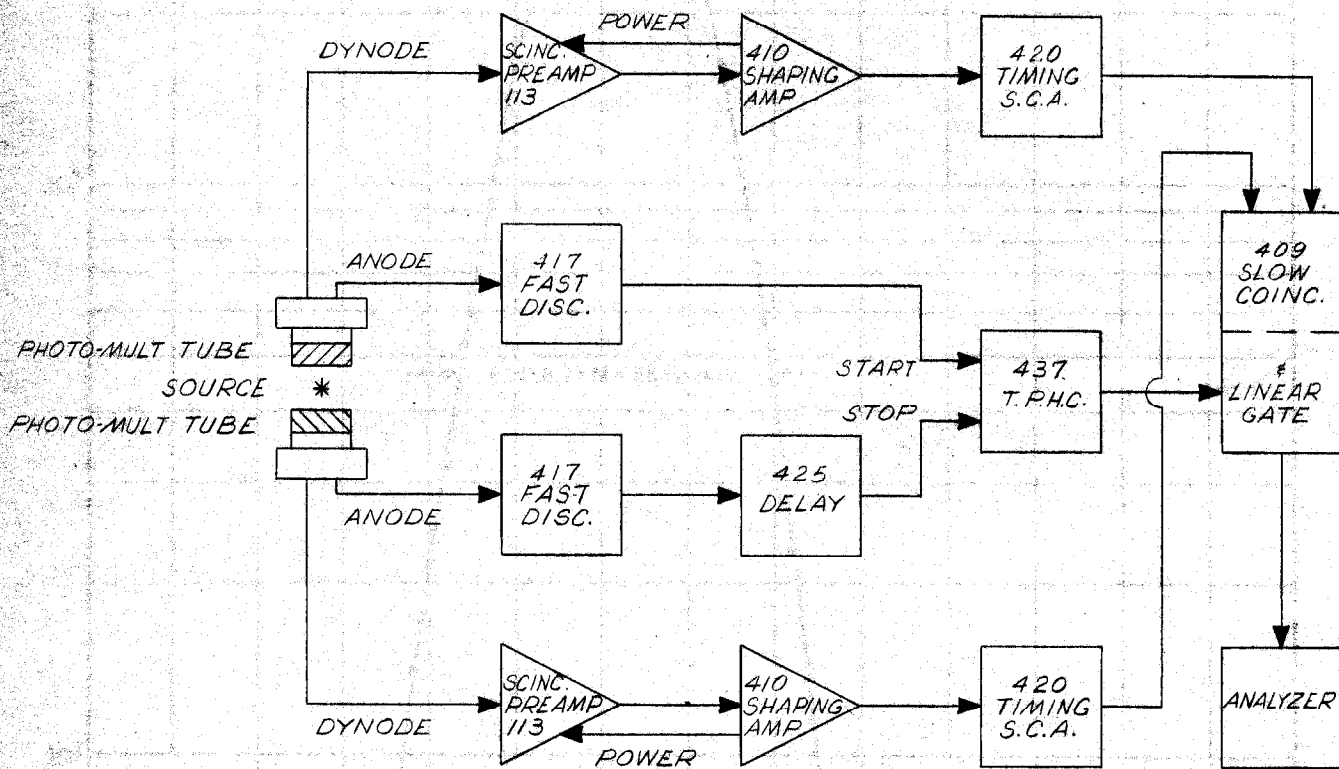

Figure 3. Simple Fast-Slow Coincidence System

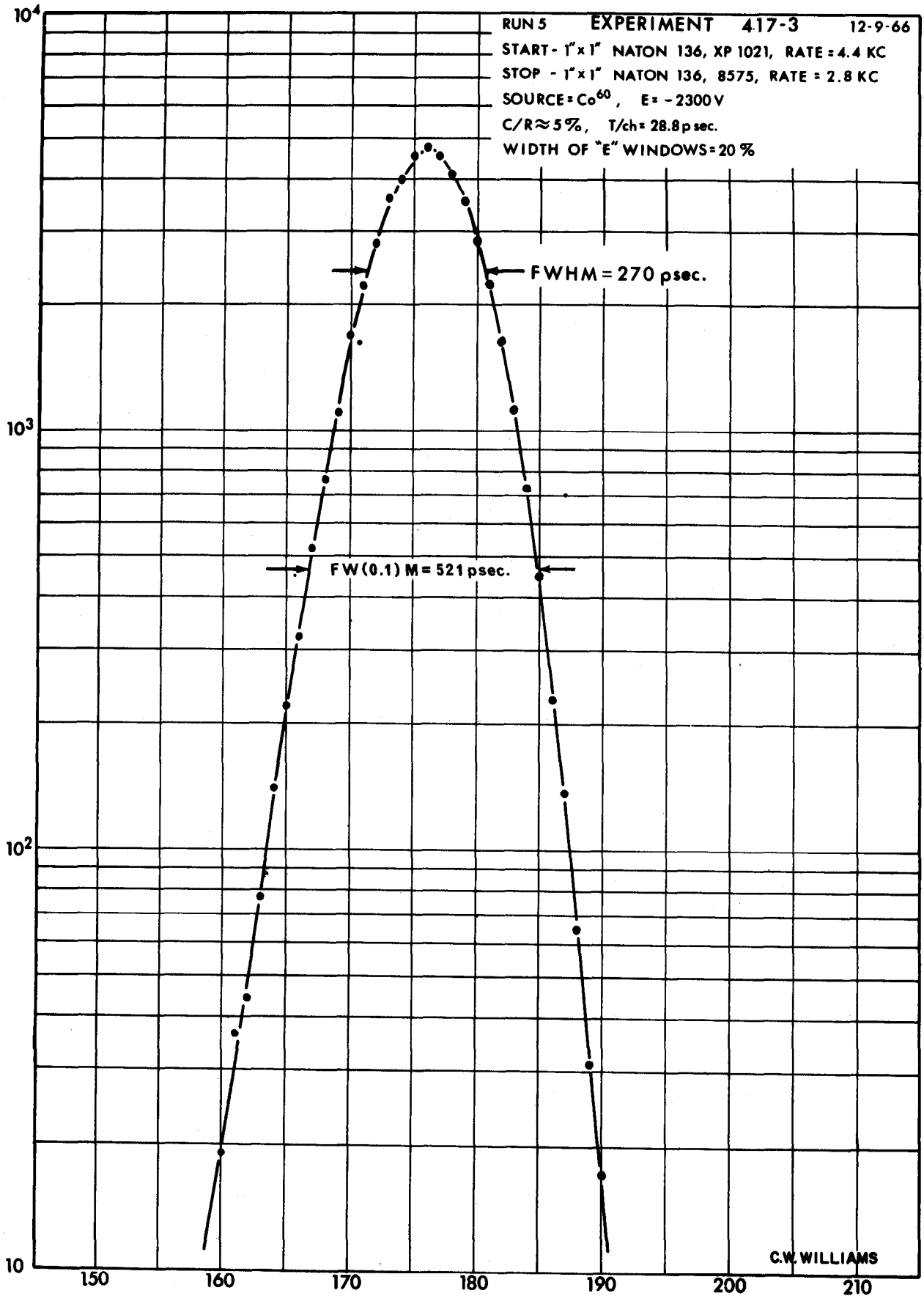

Figure 4. A Typical Coincidence Spectrum Using Plastic Scintillators

4.3.2 Typical Fast-Slow Coincidence Using NaI (TI)

The block diagram of Figure 3 applies equally well here. The difference in the two systems is the scintillator and its decay characteristic. This decay time constant is $0.25\mu\text{sec}$, whereas the same time constant for Naton 136 is approximately 2 nsec. With NaI (TI) much more total light is produced per equivalent energy event, but the collection of this light is over such a wide period of time, as indicated, that the time resolution is poorer than that of plastic. Figure 5 (page 4-6) is a typical spectrum taken with a $1\frac{1}{2}'' \times 1''$ NaI (TI) on one side of the coincidence system.

4.3.3 Fast Coincidence Using Ge (Li-drift) Detectors

Some recent experiments have been performed using a $1\frac{1}{2}'' \times 1''$ NaI (TI) in a $\gamma-\gamma$ coincidence arrangement with an ORTEC 10cm^3 Ge (Li-drift) coaxial detector, as shown in Figure 6. In this case, the radiant energy from the source was not collimated at all, so that the time is given by collection from all parts of the detector. The source viewed one end of the germanium detector. Side channels selected the energy region of interest, which was the photopeak on each side. The full time spectrum is given in Figure 7 (page 4-7). Full width at half maximum and full width at one-tenth maximum are indicated. This, when compared with published timing curves⁴, indicates a far superior detector design for timing purposes. The efficiencies associated with the FWHM and the FW (0.1) max points are 60% and 92% respectively.

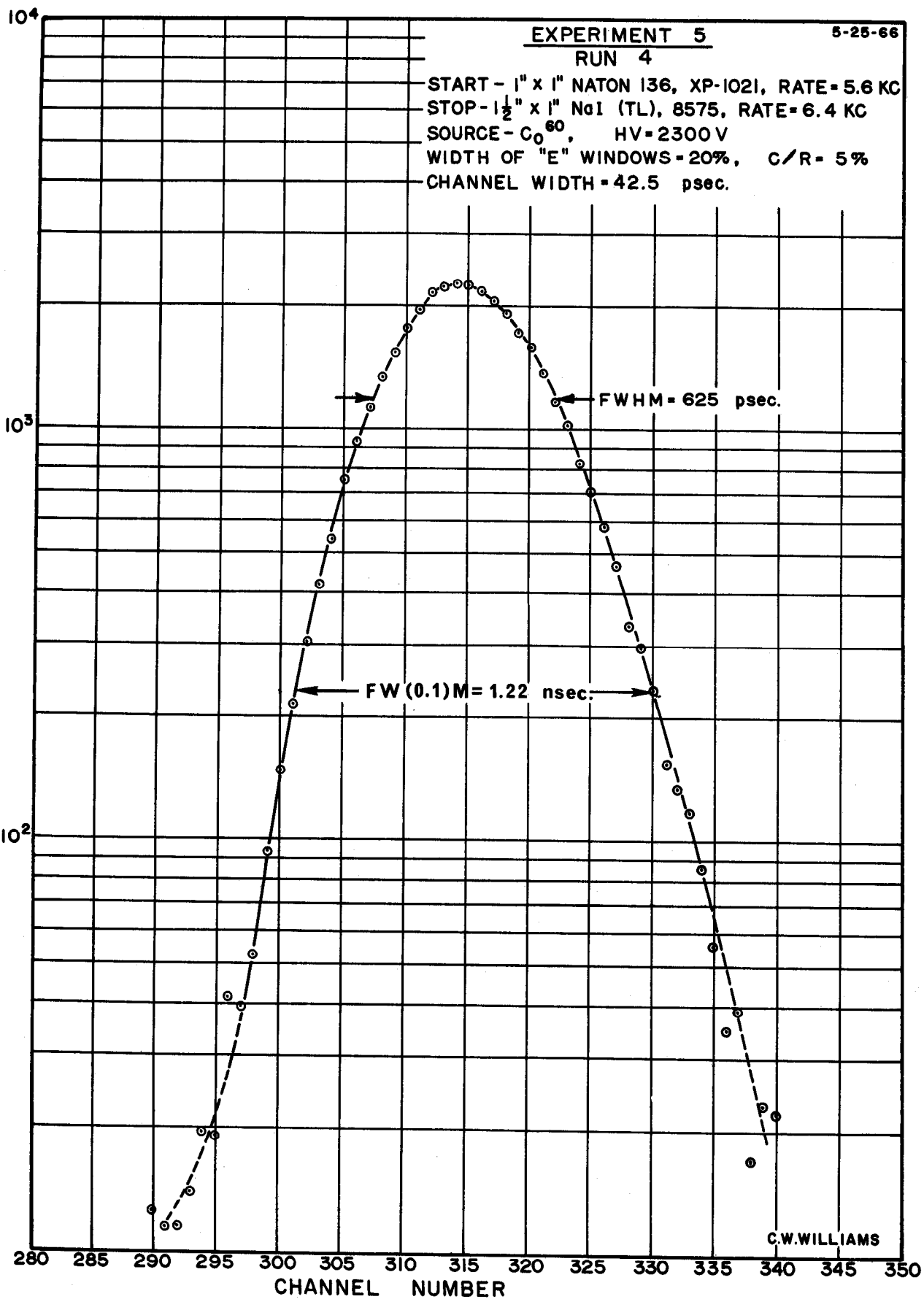

Figure 5. A Typical Coincidence Spectrum Using NaI (TL) Scintillator

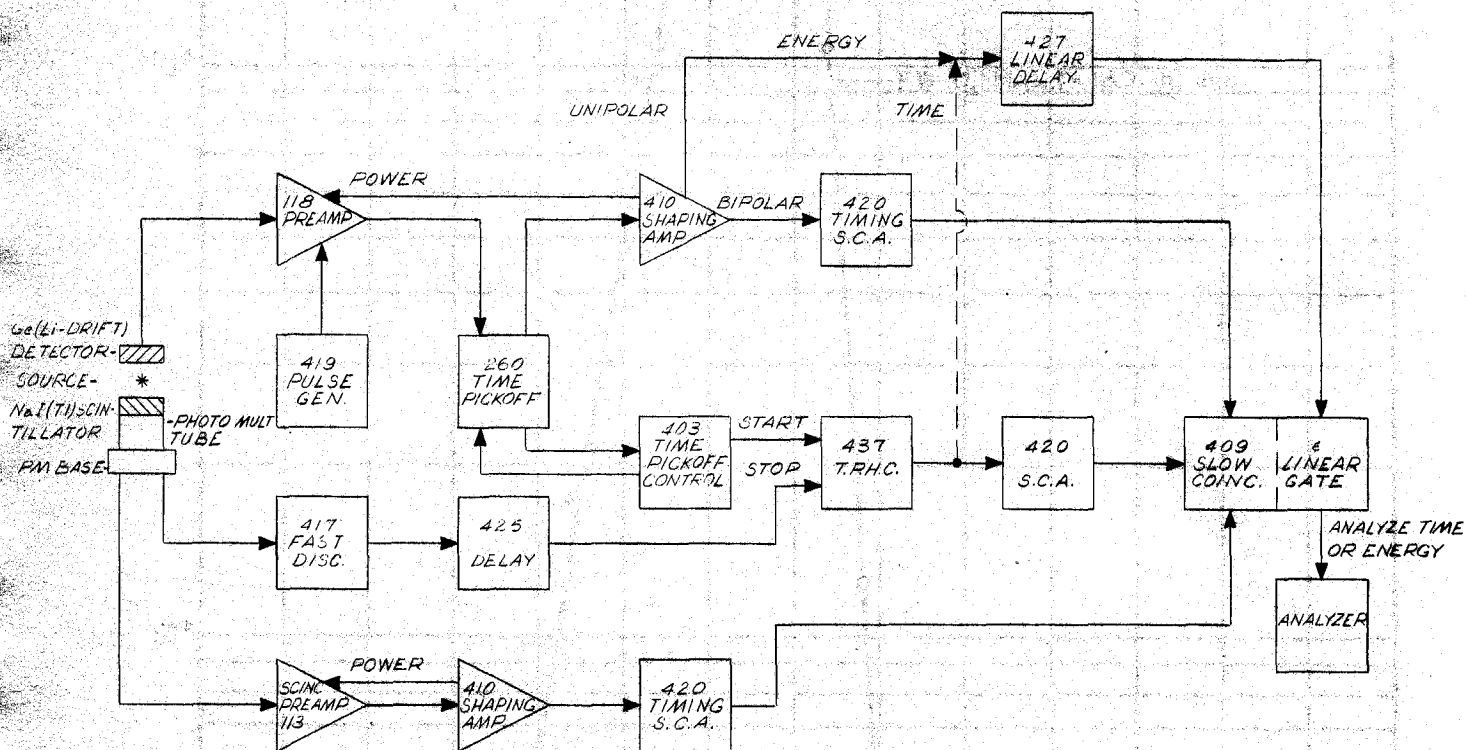

Figure 6. Gamma-gamma Coincidence System With a Ge (Li-drifted)

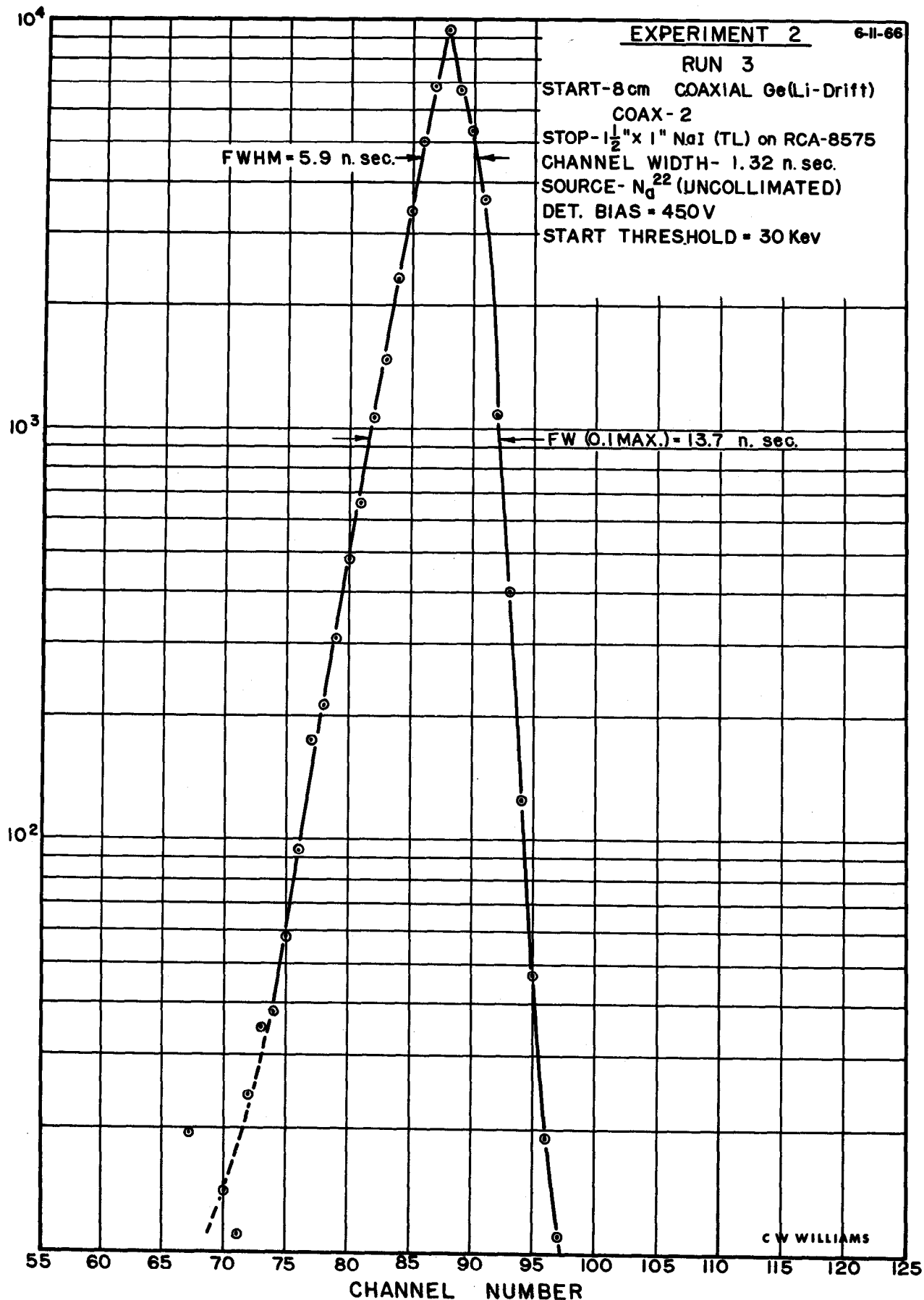
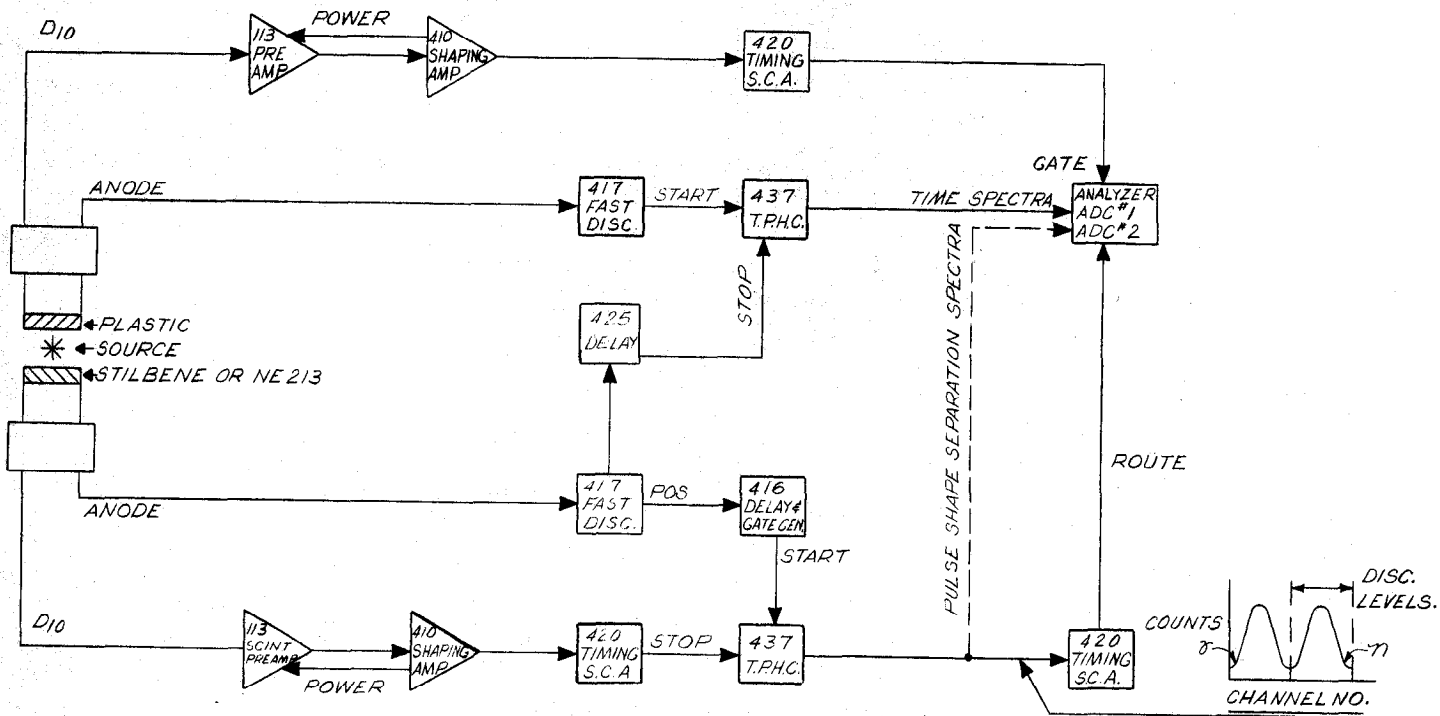

Figure 7. Timing Spectrum With Ge (Li-drifted) Detector

4.3.4 System Block Diagrams

A number of experimental systems are shown in the enclosed block diagrams for the aid of the user.



Fast-Fast Coincidence (PMT) With Pulse Shape Discrimination

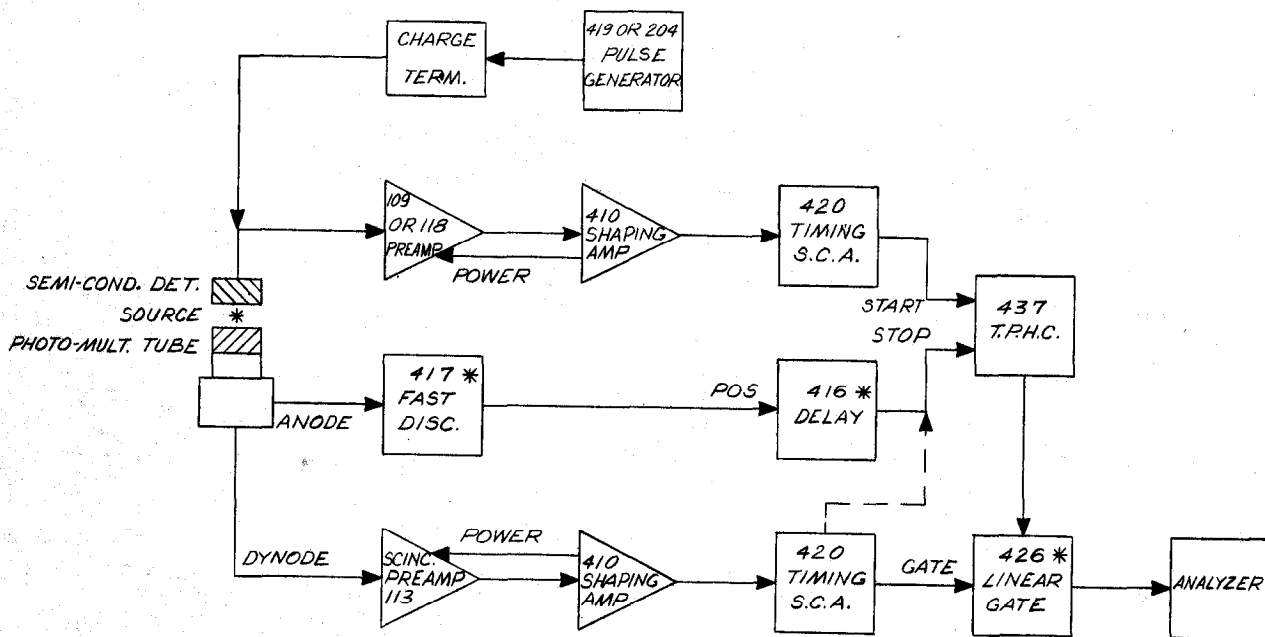

* OPTIONAL - NOT NEEDED IF CROSSOVER TIMING IS CHOSEN.

Fast Timing for (Semi-conductor Detector PMT) Coincidence Using Crossover Pickoff Technique

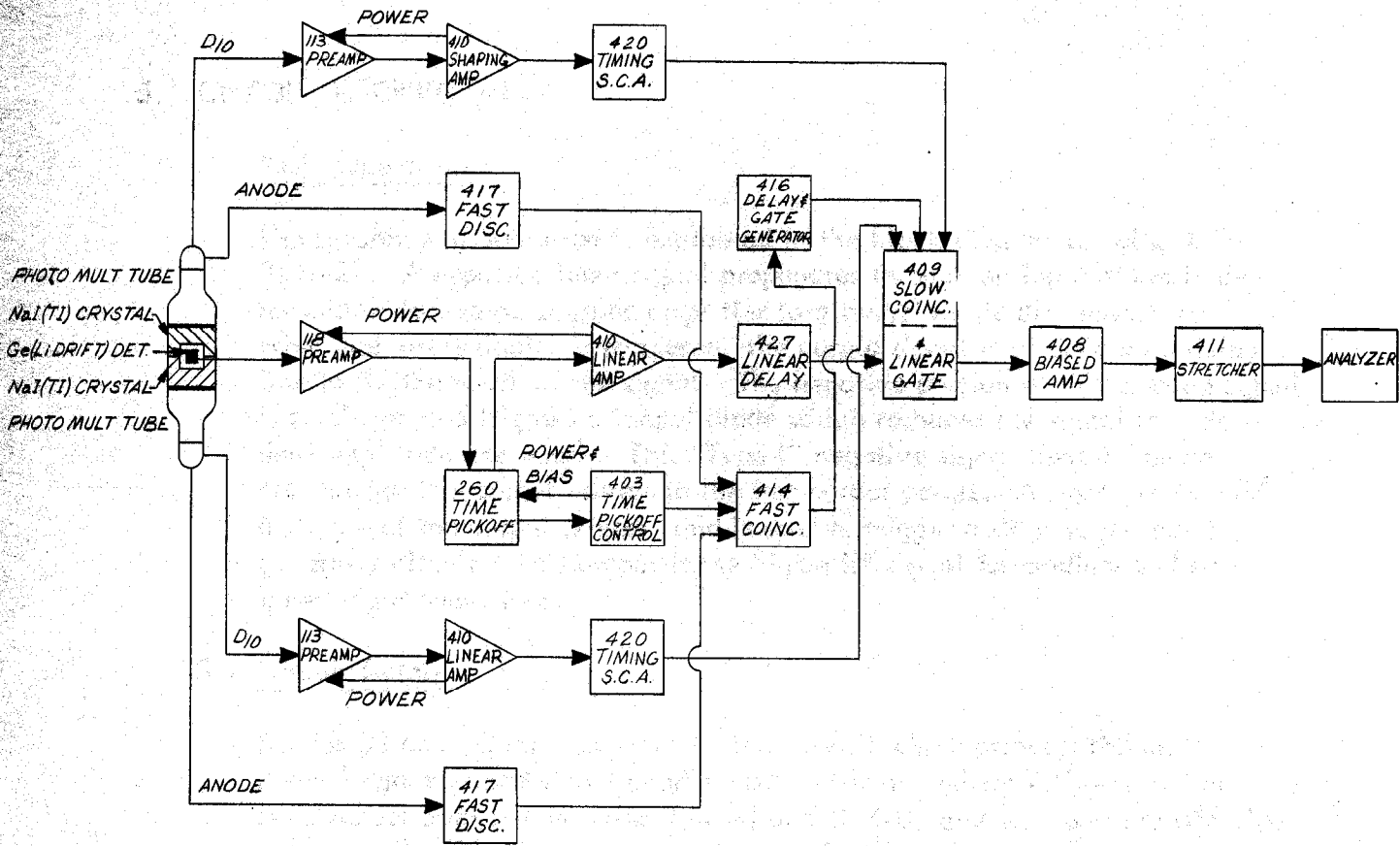

Gamma Ray Pair Spectrometer

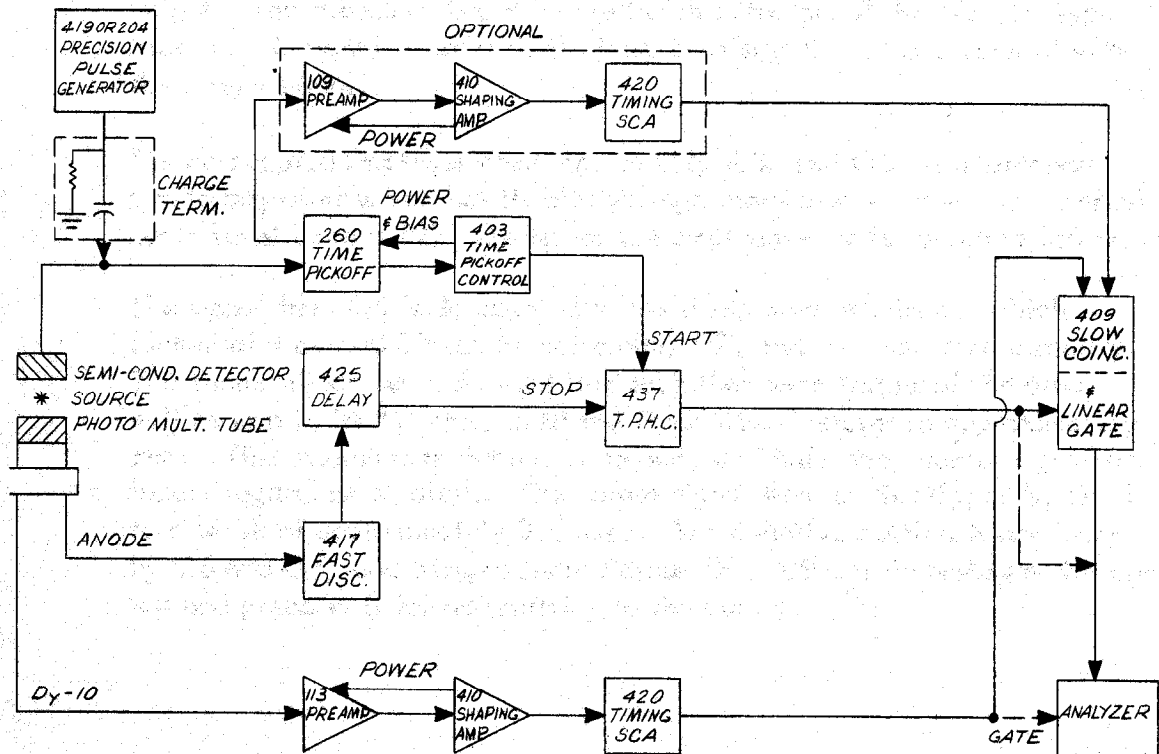

Sub-Nano Second Timing System (Semi-Conductor - Photo

5. CIRCUIT DESCRIPTION

5.1 Basic Operation

The sequence of operation is explained in the block diagram drawing 417-0101-B1. A negative input signal propagates through an input diode limiter and wideband dc coupled amplifier to a tunnel diode discriminator. When the discriminator is triggered, the output signal is clipped by a delay line to fix the width of the signal. The negative portion of this clipped signal is amplified and triggers a tunnel diode which reshapes the signal to a standard amplitude and width. This "Type I" negative signal then is fanned out through two output drivers to the fast output points. A signal is derived from one of the output drivers, and is used to trigger a slow output pulse generator circuit. This output is the "Type II" signal for medium and slow speed logic operations.

5.2 Circuit Detail

Diodes D1 and D2 form an input limiter circuit which protects the unit under large overload signal conditions. Q1 is an emitter follower which is driver for both the amplifier formed of Q2, Q3, and Q5, and the stretcher (when used). When the stretcher is set to "OUT", the stretch capacitor C4 is removed from the circuit and the idle current is increased. With the stretcher switched to "IN" the capacitor C4 is charged to the amplitude of a negative input signal and is discharged with a constant current of approximately 1 mA. This makes the stretch period proportional to pulse height. The stretcher should be used with detectors of the NaI (TI) type because this signal is not a single long-term signal, but is a burst of very short-term signals.

The dc coupled amplifier composed of Q2, Q3, and Q5, is a wideband biased amplifier which has its bias voltage input derived from the Discriminator Level control R22. Q4 serves to compensate for temperature effects of Q1

The signal from Q5 is dc coupled to the discriminator element which is formed of a current biased tunnel diode, D7, and its associated circuitry. This tunnel diode has a dc load line such that once triggered the diode will remain in its "1" state until the input signal returns to approximately zero. This assures that there will be one, and only one, output signal per input, regardless of width. The output signal from D7 is clipped by DL-1 to a width of approximately 3.5 nsec. The negative portion is amplified by Q6 and Q7, and triggers tunnel diode D9. D9 merely reshapes the signal and prepares it for transmitting to the output.

The signal from D9 feeds two identical output stages in parallel. These are formed of Q8-9-10 and Q12-13-14. Only one output stage is described. Q8 is an emitter follower buffer for the current switch output driver pair Q9 and Q10. The output signal is limited at approximately 1.2V by D10 and R46 when the 50-ohm output termination is removed. The circuit may be operated without terminations on the unused outputs; however, it is recommended that the negative signals be terminated even when not in use.

A signal is derived from the collector of Q13, which triggers the positive signal output pair, Q15-Q16. In steady state, the collector current of Q16 holds the emitter follower Q17 in the off condition. When the circuit is triggered, the pulse width is determined by C18, R74, and R60, and the output amplitude is determined by the voltage divider R73 and 75.

6. MAINTENANCE

6.1 Testing Performance

The following test equipment is needed:

- (1) Pulse Generator, HPA-222A or equivalent
- (2) Tektronix Model 661 Sampling Oscilloscope or equivalent
- (3) Vacuum tube voltmeter

Preliminary Procedures:

- (1) Visually check module for possible damage due to shipment.
- (2) Insert module into ORTEC 401/402 AEC Standard Nuclear Instrument Module Bin
- (3) Switch on power to Bin.
- (4) Check power supply voltages if equipment other than ORTEC uses power from Bin. (See Section 3.2)

6.1.1 Connections

- (1) Set the pulse generator to negative output, pulse width approximately 20 nsec, amplitude approximately 200 mV, and connect to the input connector of 417 via 50-ohm coaxial cable.
- (2) Set discriminator level adjust, R22, to minimum (150 div = 150 mV).
- (3) Connect output 1 to scope input via 50-ohm coaxial cable. There should now be an output of approximately 600 mV, negative, 4 nsec wide.
- (4) Observe rise time, width, delay, etc.
- (5) Observe output 2 and 3. (Care should be taken to attenuate signal from output 3 to prevent scope damage).

6.1.2 Adjustments (All adjustments are made at the factory, and there should rarely be need for readjustment.)

There are only two controls associated with the unit other than the Discriminator Level Control. These are the Discriminator Zero adjustment (R23) and the Output Shaper Bias (R41).

Setting of Discriminator Zero:

- (1) Set Discriminator Level to minimum (150 divisions).
- (2) Apply input signal of 150 mV. (Care should be taken to assure that the baseline of the input signal be zero volts, since the discriminator bandwidth extends down to dc.)
- (3) Adjust R41 to obtain triggering at this input signal level. This fixes the input threshold (minimum) at 150 mV. This control may be varied enough to set D4 into the "1" state. If this condition is imposed, no output is possible.

Note: It is important to note that, due to the delicate bias conditions, a low impedance probe will upset the operation of the circuit under certain conditions. When this happens, the characteristic operation is multiple output signals with wide input signals.

Setting of Output Shaper Bias:

The pulse shaper bias control R41 is not critical, and is normally set mid-range between oscillation and no output when the discriminator element D9 is being triggered by an input signal.

6.2 Tabulated Test Point Voltages

The following voltages are intended to indicate the typical dc voltages measured on the circuit board. The voltages given here should not be taken as absolute values; rather, they are intended to serve as an aid in troubleshooting.

TABLE 1
Typical DC Voltages

Conditions: Discriminator Level - 100
No signal input
Meter - VTVM

<u>Test Point</u>	<u>Voltage</u>
+ 24V bus	+ 23.7
+ 12V bus	+ 11.7
- 12V bus	- 11.2
- 24V bus	- 23.5
Q1B	+ 0.020
Q1E	+ 0.75
Q1C	- 0.75

TABLE 1
Typical DC Voltages (Cont'd)

<u>Test Point</u>	<u>Voltage</u>	
Q2C	+ 1.3	
Q3C	+ 0.48	
Q3B	+ 0.62	Varies with Disc. Level
Q4B	- 0.11	
Q5C	- 0.05	
Q7C	- 0.7	
Q8B	- 0.080	
Q9B	- 0.88	
Q10B	- 1.10	
Q13B	- 0.88	
Q15C	0	
Q16B	- 11.0	
Q17B	- 0.015	

6.3 Factory Service

The 417 may be returned to ORTEC for repair service at nominal cost. The standardized procedure requires that each repaired instrument receive the same extensive quality control tests that a new instrument receives.

**BIN/MODULE CONNECTOR PIN ASSIGNMENTS
FOR AEC STANDARD NUCLEAR INSTRUMENT MODULES
PER TID-20893**

Pin	Function	Pin	Function
1	+3 volts	23	Reserved
2	-3 volts	24	Reserved
3	Spare Bus	25	Reserved
4	Reserved Bus	26	Spare
5	Coaxial	27	Spare
6	Coaxial	*28	+24 volts
7	Coaxial	*29	-24 volts
8	200 volts dc	30	Spare Bus
9	Spare	31	Carry No. 2
*10	+6 volts	32	Spare
*11	-6 volts	*33	115 volts ac (Hot)
12	Reserved Bus	*34	Power Return Ground,
13	Carry No. 1	35	Reset
14	Spare	36	Gate
15	Reserved	37	Spare
*16	+12 volts	38	Coaxial
*17	-12 volts	39	Coaxial
18	Spare Bus	40	Coaxial
19	Reserved Bus	*41	115 volts ac (Neut.)
20	Spare	*42	High Quality Ground
21	Spare	G	Ground Guide Pin
22	Reserved		

**These pins are installed and wired in parallel in the ORTEC Model 401 Modular System Bin.*

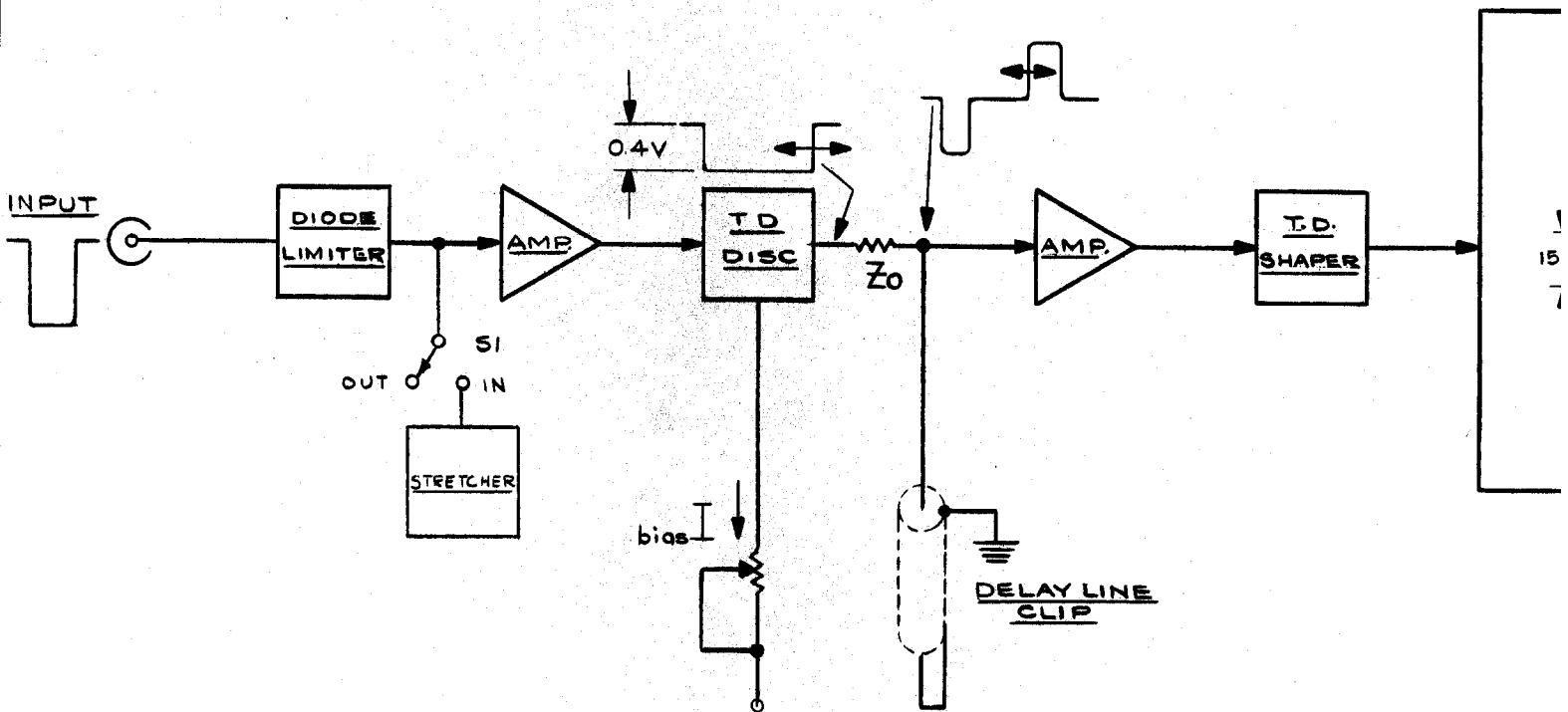

REVISIONS				UNLESS SPECIFIED	
REV.	ECN. NO.	DATE	BY	DIMENSIONS	TOLERANCE
B	417-3	12-16-67	JDM	FRACTION	
A	417-2	12-14-64	JDM	DECIMALS	
				ANGLES	
				SURFACE FINISH	
				APPLIED PRACTICE	

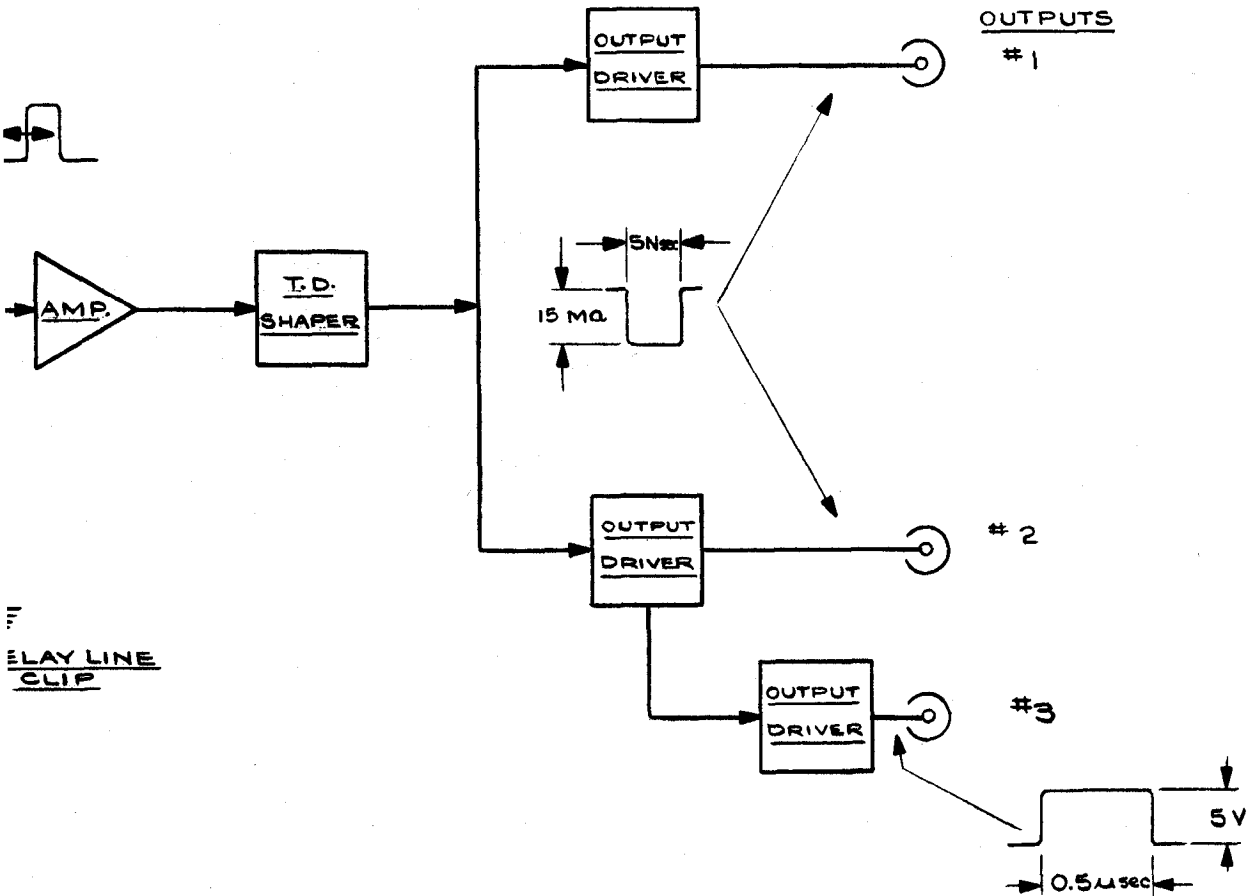

REVOLUTIONS		UNLESS OTHERWISE SPECIFIED		ORTEC		OAK RIDGE TECHNICAL ENTERPRISES CORPORATION	
REV.	ECN. NO.	DATE	BY	APPD.	OAK RIDGE TENNESSEE		
B	417-3	12-14-67	JDM		TITLE		
A	417-2	12-14-67	JDM		FAST DISCRIMINATOR		
					BLOCK DIAGRAM		
DIMENSIONS IN INCHES				DRAFTSMAN			
TOLERANCES				HLY			
FRACTION ±				DATE			
DECIMALS ±				5/20/66			
ANGLES ±				ENG. APPROVAL			
SURFACE FINISH ✓ RMS				C.A. Williams			
APPLIED PRACTICES				DATE			
				6/30/66			
				MFG. APPROVAL			
				MS			
				DATE			
				6/30/66			
				DWG. ISSUED			
				WRP			
				DATE			
				7-20-66			
RESP. ENG.						DRAWING NO.	
C. WILLIAMS						417-0101-B2	

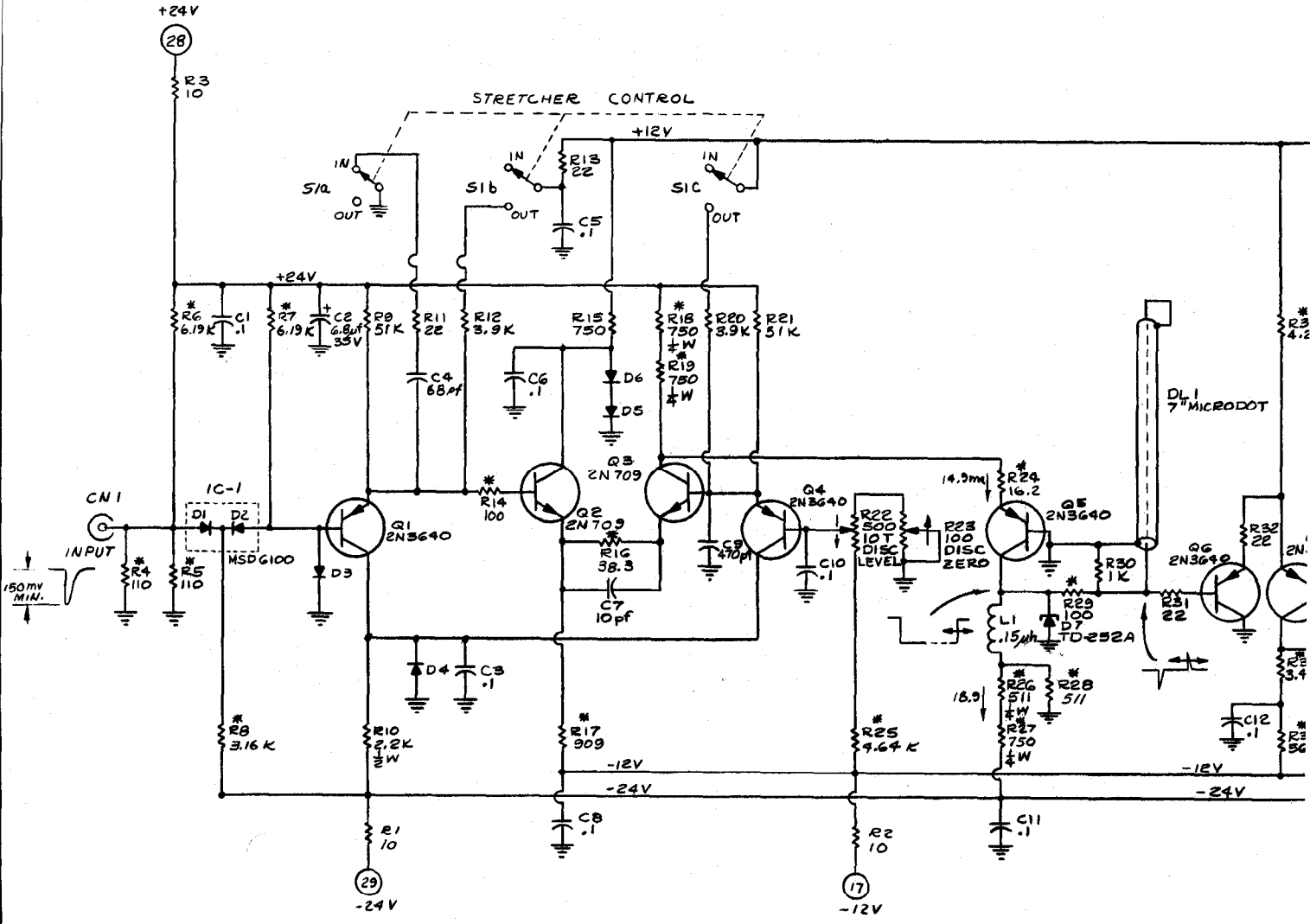

- Notes:
- Unless otherwise specified:
1. All diodes are 1N4009.
 2. Resistors marked (*) are metal film 1%, 1/8 W. (T-O)
 3. All IC's - MSD-6100

LI-L3
 Q1-Q17
 DI-D12
 CI-C21
 RI-R66

The transistor types installed in your instrument may differ from those shown in the schematic diagram. In such cases, necessary replacements can be made with either the type shown in the diagram or the type actually used in the instrument.